

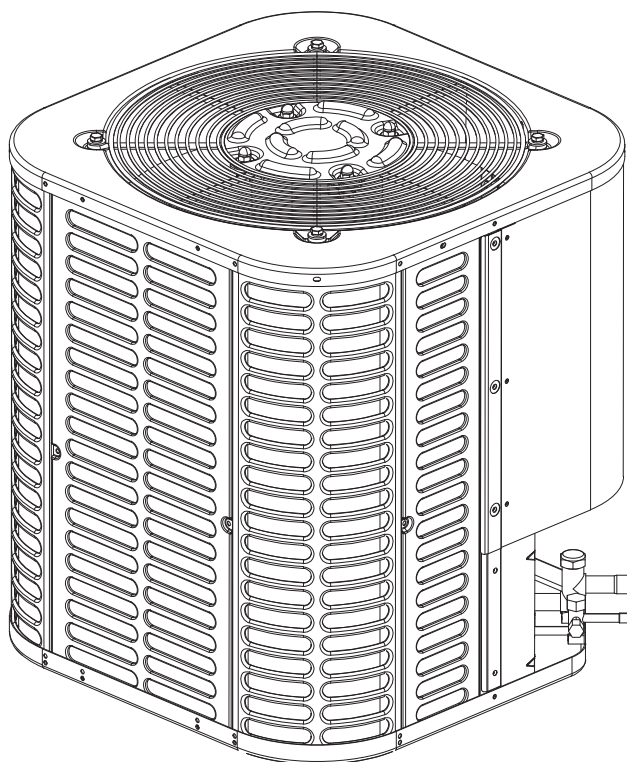

INSTALLATION INSTRUCTIONS

Split System Heat Pump & Air Conditioner

Model Size:
1.5, 2, 2.5, 3, 3.5, 4, 5 Tons
R410A



CONTENTS

1. Symbol and Key to Safety Instructions.....	01
2. Considerations of Unit Location	04
3. Unit Installation Preparation	09
4. Unit Settings	09
5. Precautions for Refrigerant Pipeline.....	10
6. Refrigerant Pipeline Routing	12
7. Refrigerant Pipeline Brazing.....	14
8. Refrigerant Pipeline Leakage Inspection.....	15
9. Evacuation.....	17
10. Service Valve.....	18
11. Electrical-Low Voltage	19
12. Electrical-High Voltage	24
13. Start.....	25
14. System Refrigerant Charging Regulation	26
15. System Operation and Troubleshooting	28
16. Wiring Diagram.....	35
17. Cleaning and Maintenance.....	37

1. Symbol and Key to Safety Instructions

1.1 Symbol Keywords



WARNING

The warnings in this document are identified by warning triangles printed on a gray background. The key words at the beginning of the warning indicate the type and severity of the next risk if no measures are taken to prevent it.

The following keywords are defined and used in this document:



Danger

Indicates a dangerous situation, which, if not avoided, will lead to death or serious injury.



Warning

Indicates a dangerous situation, which, if not avoided, may lead to death or serious injury.



Caution

Indicates a dangerous situation, which, if not avoided, may cause mild to moderate injury.



Note

Used to deal with behaviors unrelated to personal injury.

Important information



This symbol represents important information that is not dangerous to people or property.

1.2 Safety

Please Read Before Continuing.



WARNING



Failure to observe this warning may result in property damage, serious personal injury or death.



Before touching the electrical components, wait for 3 minutes after disconnecting the power supply.



NOTICE



This document is the property of the customer and is kept by this unit. When you are finished, please return to the service information package.



These instructions do not cover all changes in the system, nor do they provide all unexpected situations that may be encountered during installation.



If you need more information, or there are special problems that are not sufficient for the buyer, you should consult your installation dealer or local dealer.



Some benefits of installing an approved indoor and outdoor split system are maximum efficiency, best performance and best overall system reliability.



This document contains wiring diagram and maintenance information. This is the customer's property and belongs to this unit. When you are finished, please return to the service information package.

Warning:



- This appliance is not intended for use by persons (including children) with reduced physical, sensory or mental capabilities, or lack of experience and knowledge, unless they have been given supervision or instruction concerning use of the appliance by a person responsible for their safety.
 - The appliance shall be installed in accordance with national wiring regulations.
 - Children should be supervised to ensure that they do not play with the appliance.
 - Before accessing the connection terminals, all power circuits must be disconnected.
 - This information is intended for use by individuals with sufficient electrical and mechanical experience background. Attempting to repair central air conditioning products may result in personal injury and/or property damage.
-

Warning: Dangerous voltage



- Failure to observe this warning may result in property damage, serious personal injury or death.
 - Disconnect all power before maintenance, including remote disconnection. Follow proper locking/tagging procedures to ensure that the power supply will not be energized accidentally.
-

Warning: Refrigerant oil



- Attempting to repair central air-conditioning products may result in property damage, serious personal injury or death. These units use R-410A refrigerant, and its working pressure is 50-70% higher than R-22. Use only the service equipment approved by R-410A. The refrigerant cylinder is painted "rose" to indicate the type of refrigerant, and may contain a "dip" tube to allow liquid refrigerant to be filled into the system. All R-410A systems use POE oil (VG74 or equivalent), which can easily absorb moisture from the atmosphere. In order to limit this "moisture absorption" effect, the system should be sealed as much as possible. If the system is exposed to the atmosphere for more than 4 hours, the compressor oil must be changed. Do not destroy the vacuum with air, and always replace the dryer when you open the system for component replacement.
-

Warning: Hot surface



- May cause mild to severe burns. Failure to observe this caution may result in property damage or personal injury. Do not touch the top of the compressor.
-

Caution: Contains refrigerant



- Failure to follow the correct procedures will lead to personal illness or injury or serious equipment damage. The system contains high-pressure oil and refrigerant. Before opening the system, recover the refrigerant to release the pressure.
-



Note: Indoor unit is required

- Indoor unit is equipped with piston or TXV, and the model of piston and TXV is selected by manufacturer, please do not change by yourself.
-



Note: Grounding is required

- Failure to check or use the correct maintenance tools may result in equipment damage or personal injury. Reconnect all grounding devices. All parts of this product that can conduct current are grounded. If the grounding wire, screw, strap, clip, nut or washer used to complete the grounding path is removed during maintenance, it must be put back in place and properly fixed.
-



Warning: service valve

- Failure to observe this warning will result in sudden discharge of system charge, which may result in personal injury and/or property damage. When opening the liquid pipeline service valve, be extra careful. Turn the valve stem counterclockwise until the valve stem touches the bead.
-



Warning: Brazing is required

- Failure to check the wiring or use the correct maintenance tools may result in equipment damage or personal injury. If using existing refrigerant lines, make sure that all joints are brazed, not soldered.
-



Warning: High current leakage

- Failure to observe this warning may result in property damage, serious personal injury or death. Before connecting the power supply, grounding is essential.
-



Warning:

- This product may expose you to chemicals including lead and lead components, which are known to cause cancer, birth defects or other reproductive harm in California. For more information, please visit www.P65Warnings.ca.gov.
-

2. Considerations of Unit Location

2.1 Unit Size

Table 2.1 Outdoor Operating Temperature

Model	Temperature
Cooling mode	58-115°F
General heat pump mode	15-75°F
High vertical heat pump mode	23-75°F

Table 2.2

Unit size	
Model	H x W x L (inches)
18K/24K(AC)	25 x 21-4/5 x 21-4/5
24K(HP)/ 30K/36K	25 x 29-1/7 x 29-1/7
42K/48K/60K	32-7/8 x 29-1/7 x 29-1/7

The weight of the unit is attached to the carton.

When installing the outdoor unit on the roof, make sure that the roof can support the weight of the outdoor unit. It is recommended to choose appropriate isolation to prevent sound or vibration from being transmitted to the building structure.

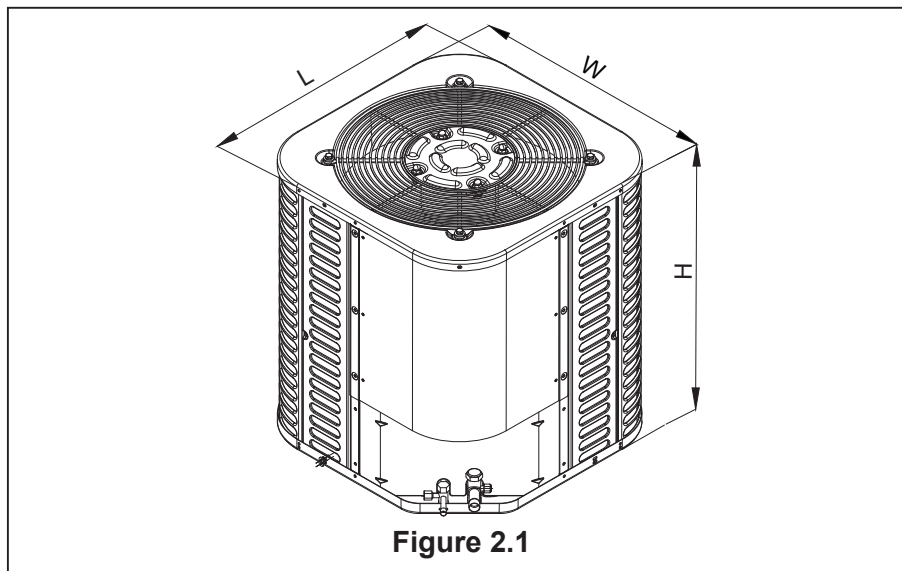

2.2 Refrigerant Pipeline Restriction

Table 2.3 Heat pump types in general mode

Refrigerant Piping		Capacity (Kbtu/h)						
		18K	24K	30K	36K	42K	48K	60K
Liquid-Gas	In.	3/8-3/4	3/8-3/4	3/8-3/4	3/8-3/4	3/8-3/4	3/8-7/8	3/8-7/8
Max. Refrigerant Line Length*	Ft.	100				150		
Max. Vertical Lift	Ft.	26				33		

*It is recommended to adopt standard pipeline size; Refrigerant charge: see Section 14.



- If the pipeline length or high vertical of the above models exceeds the data in Table 2.3, please set the high vertical mode dip switch according to the data range in Table 2.4, and refer to Table 2.5 for the dip switch diagram.



Instructions for high vertical mode:

- For the initial power-on of the unit, the ambient temperature is lower than 73.4°F. To ensure product reliability, the compressor needs to be preheated for about four hours before starting. This is a normal phenomenon.

Table 2.4 Heat pump types in high vertical mode

Refrigerant Piping		Capacity (Kbtu/h)						
		18K	24K	30K	36K	42K	48K	60K
Liquid-Gas	In.	3/8-3/4	3/8-3/4	3/8-3/4	3/8-3/4	3/8-3/4	3/8-7/8	3/8-7/8
Max. Refrigerant Line Length*	Ft.	130						
Max. Vertical Lift	Ft.	60						

*It is recommended to adopt standard pipeline size; Refrigerant charge: see Section 14.

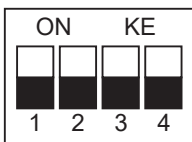

Figure 2.2

Table 2.5 Dip Switch Diagram

Dial switch	ON	OFF
SW1-2	High-vertical mode	General mode

Table 2.6 Cooling only types

Refrigerant Piping		Capacity (Kbtu/h)						
		18K	24K	30K	36K	42K	48K	60K
Liquid-Gas	In.	3/8-3/4	3/8-3/4	3/8-3/4	3/8-3/4	3/8-3/4	3/8-7/8	3/8-7/8
Max. Refrigerant Line Length*	Ft.	130						
Max. Vertical Lift	Ft.	60						

*It is recommended to adopt standard pipeline size; Refrigerant charge: see Section 14.

- ▶ Maximum equivalent length of pipeline = 130 feet.
- ▶ Maximum vertical equivalent length = 60 feet.
- ▶ Use only the pipe diameters shown in Table 2.2.
- ▶ If the suction line exceeds 60 feet, do not use a larger suction line than recommended.

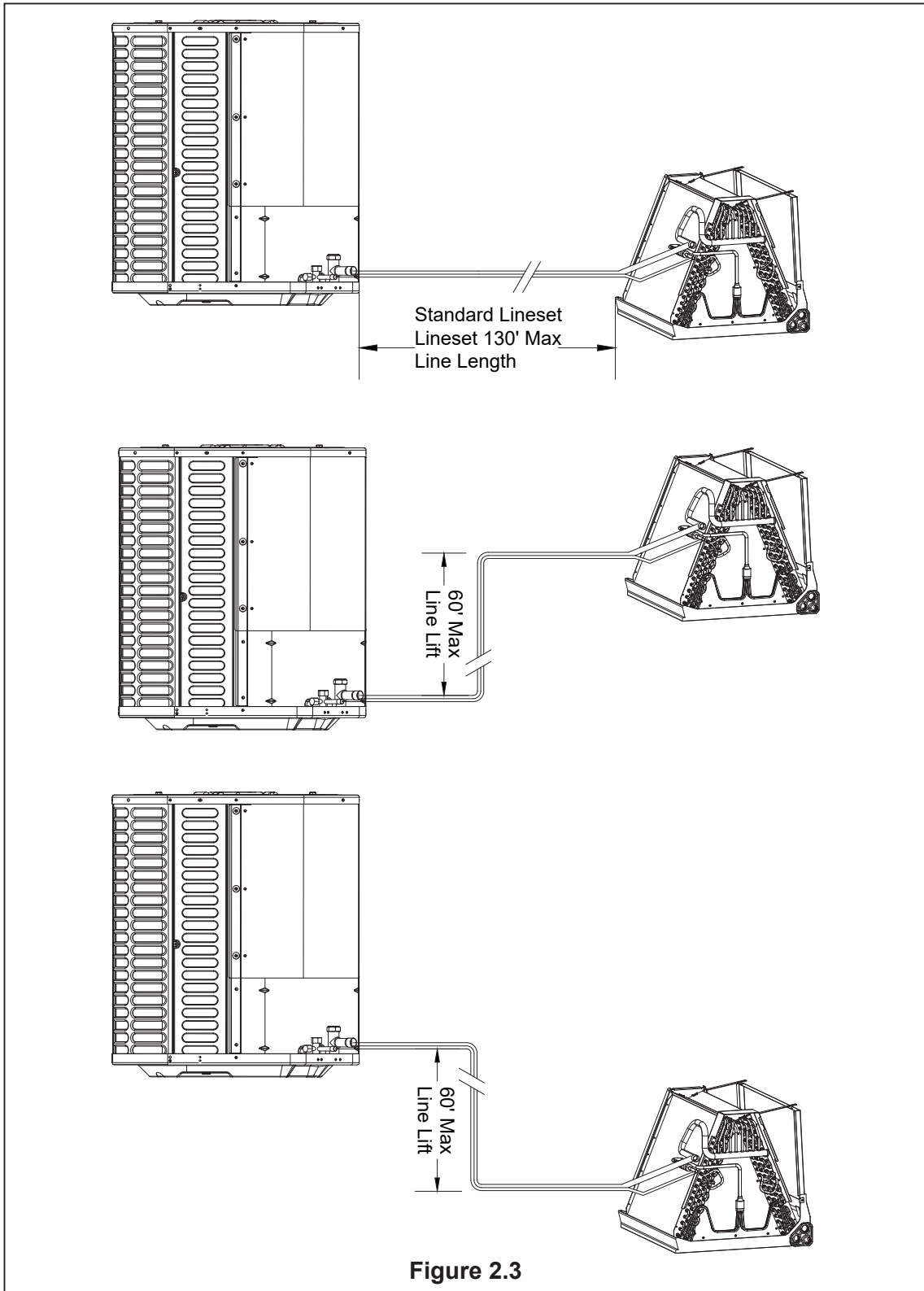
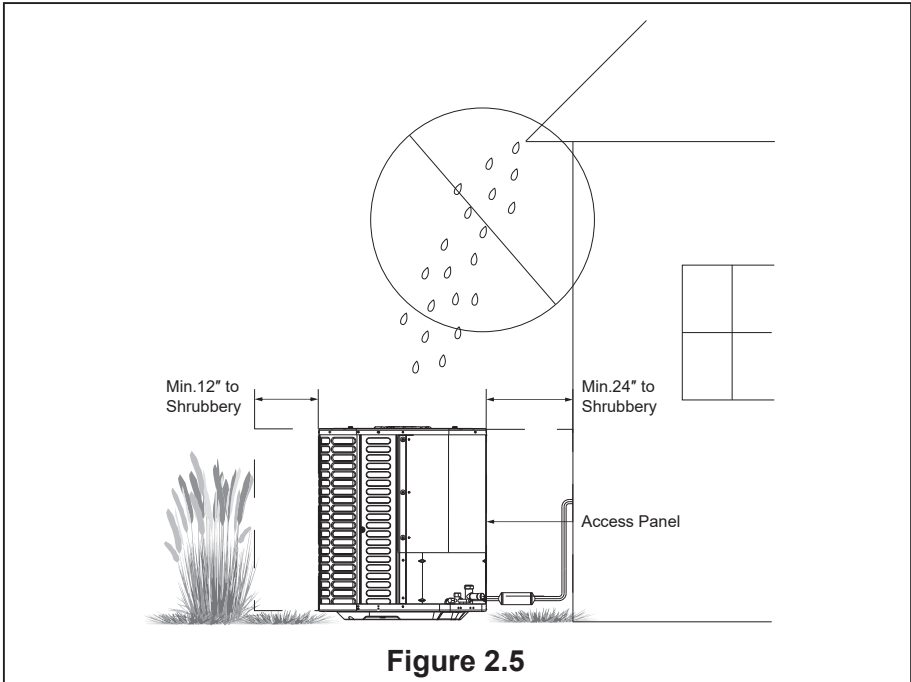
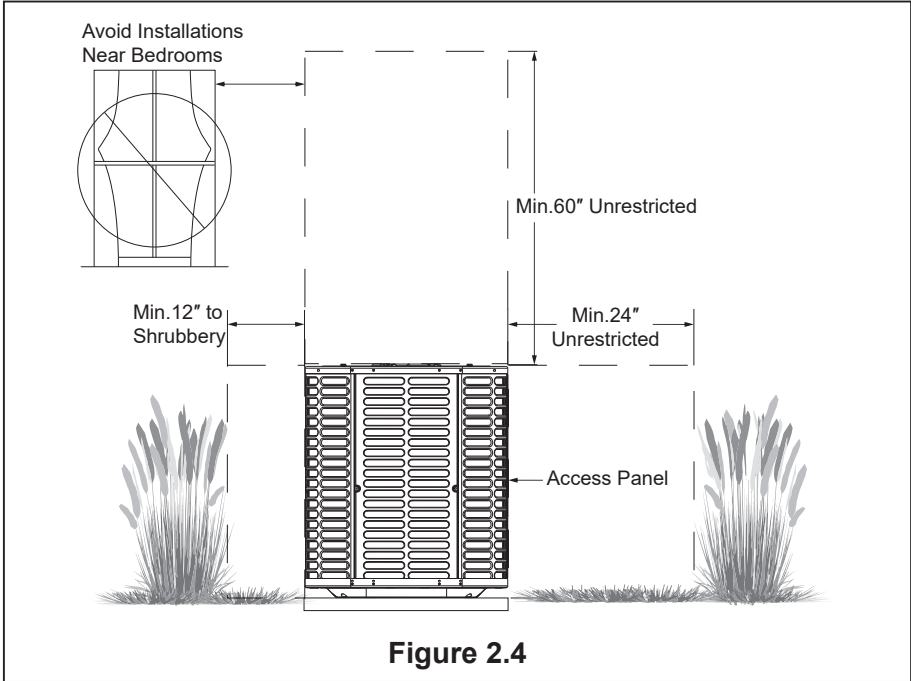

Figure 2.3

2.3 Position Restriction

- Make sure that the discharge area at least 60 inches above the top of the unit is unrestricted.
- Don't put the outdoor unit near the bedroom, because the normal operating sound may be offensive.
- Position the equipment, leaving enough space for smooth airflow, wiring, refrigerant lines and maintainability.
- 12 inches minimum is allowed. The clearance from one side of the access panel to the wall should be at least 24 inches. Next to the control panel near the panel.
- Keep a distance of 24 inches between adjacent units.
- Place the unit in a place where water, snow or ice cannot fall directly on the device from the roof or overhangs.
- See figures 2.3 and 2.4.



Precautions in cold climate (heat pump only)



Precautions must be taken for units installed in areas with snow and long-term temperatures below freezing point.

- Depending on the local weather conditions, the unit should be raised by 3-12 inches. This extra height will allow the snow and ice melted during the defrosting cycle to be discharged before re-freezing. Make sure that the drain hole on the unit chassis is not blocked, otherwise it will hinder the defrosting water discharge (Figure 2.5).
- If possible, avoid places that are prone to snow. If this is not feasible, a snow barrier should be installed around the unit to prevent snow accumulation on the side of the unit.

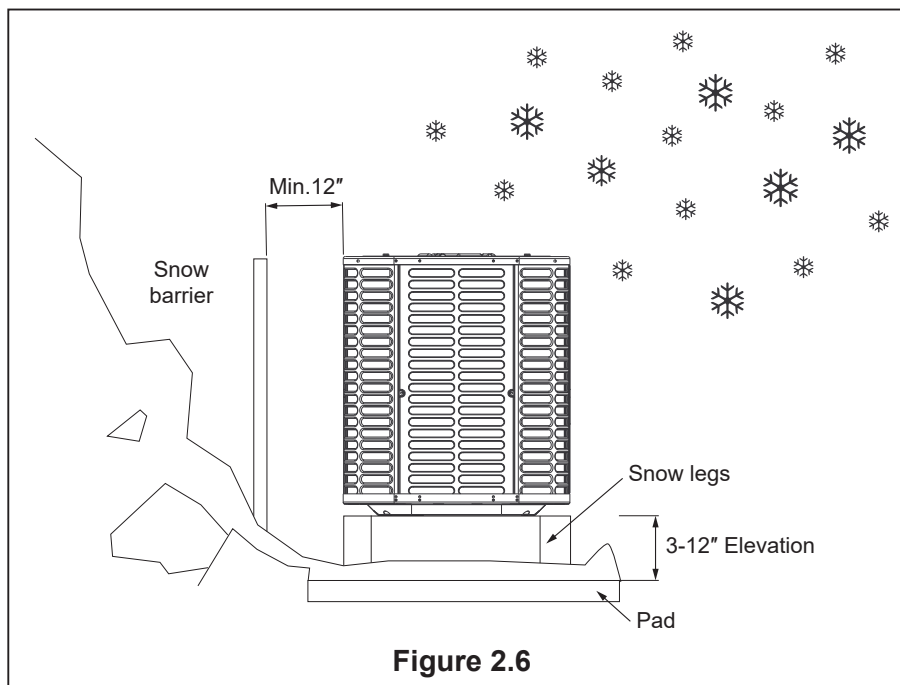

Corrosive Environment

Exposure to corrosive environment may shorten the service life of unit, corrode metal parts and/or negatively affect the performance of unit. Corrosive elements include but are not limited to: sodium chloride, sodium hydroxide, sodium sulfate and other compounds commonly found in seawater, sulfur, chlorine, fluorine, fertilizers and various chemical pollutants from industrial/manufacturing plants. If it is installed in an area that may be exposed to corrosive environment, special attention should be paid to the placement and maintenance of the unit.

- Lawn sprinklers/hoses/waste water should not be sprayed directly on the outer panel of the unit for a long time.
- In coastal areas: install the unit on the side away from the waterfront.
- Fences or shrubs can provide some shielding protection for the unit, but the minimum device clearance must still be kept.
- Clean the outdoor coil and any exposed external surfaces about every three months.

3. Unit Installation Preparation

3.1 Prepare the Unit for Installation

- Check whether there is any damage and report any damage to the unit to the carrier in time (Figure 3.1).
- Instruments can be used to ensure that the refrigerant charge is maintained during shipment.

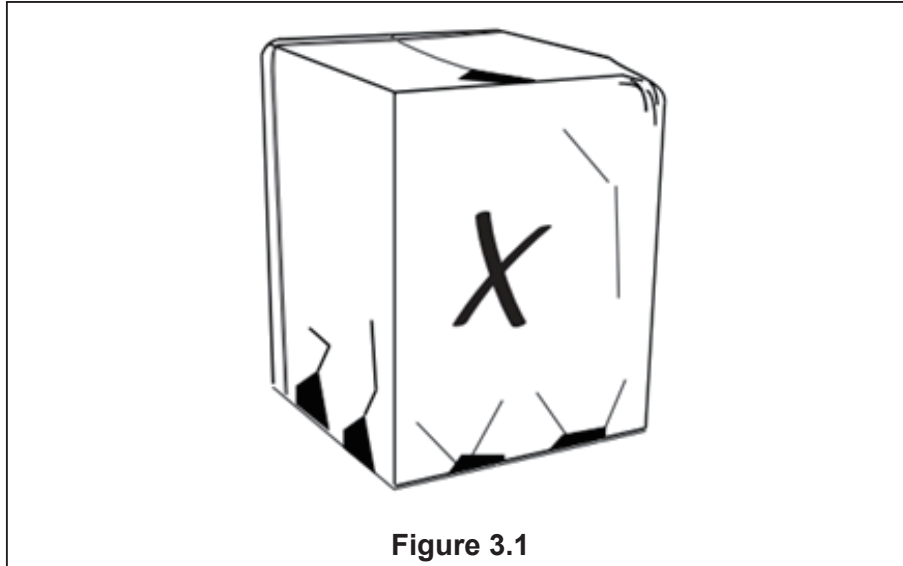

4. Unit Settings

4.1 Gasket Installation

When installing the unit on a support pad (such as a concrete slab), please consider the following:

- All sides of the pad must be at least 1-2 inches larger than the unit.
- The gasket must be separated from any structure.
- The mat must be level.
- The cushion must be high enough above the ground for drainage.
- The location of the pad must comply with national, state and local regulations.



These instructions are intended to provide a method of fixing the system to the cement slab as a fixing procedure in windy areas. Check the local regulations of tie-down methods and protocols.

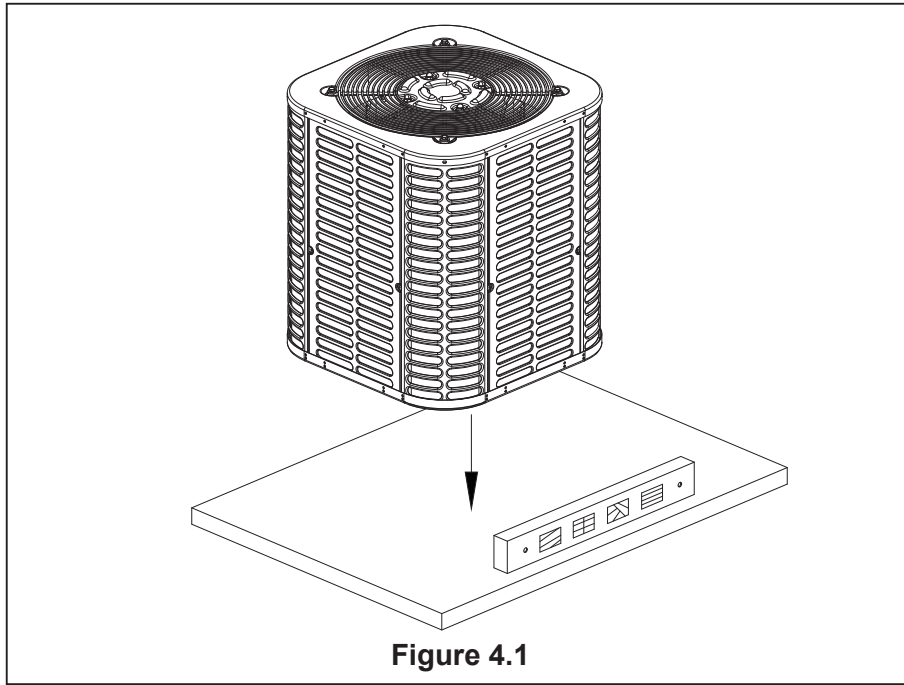

5. Precautions for Refrigerant Pipeline

5.1 Connecting Dimensions of Refrigerant Lines and Service Valves

Table 5.1

Model	Suction line	Liquid line	Suction line connection	Liquid line connection
The dimensions are in inches.				
18K/24K/30K/36K/42K	3/4	3/8	3/4	3/8
48K/60K	7/8	3/8	7/8	3/8

5.2 Length of Required Refrigerant Pipeline

Determine the required pipeline length (Figure 5.1). Please refer to Section 2.2.

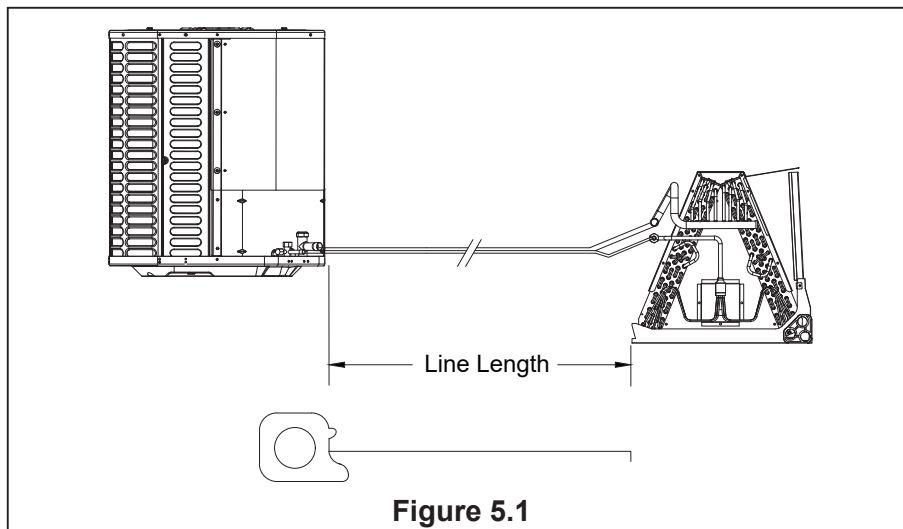

5.3 Refrigerant Pipe Insulation



The suction line must always be insulated. Do not let the liquid line and vapor line come into direct contact (metal to metal).

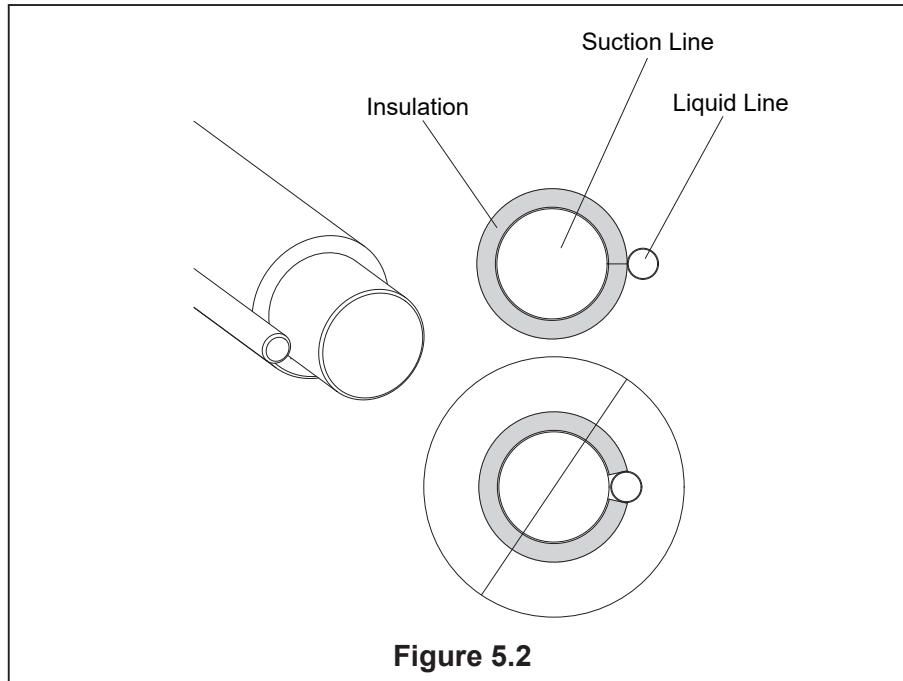

5.4 Reuse the Existing Refrigerant Lines



Note: Mild to moderate burns

- If using existing refrigerant lines, make sure that all joints are brazed, not soldered.

The following precautions should be taken for the retrofit application that will use the existing refrigerant pipeline:

- Make sure the refrigerant line size is correct. Refer to Section 2.2 and Table 2.2.
- Make sure the refrigerant line is free of leakage, acid and oil.



The manufacturer recommends that only approved matching indoor and outdoor systems be installed. All split systems are certificated by AHRI, the indoor unit is equipped with piston or TXV, and the model of piston and TXV is selected by manufacturer, please do not change by yourself. The benefits of installing an approved indoor and outdoor split system are maximum efficiency, best performance and best overall system reliability.

6. Refrigerant Pipeline Routing

6.1 Preventive Measure



Take preventive measures to prevent noise generated by vibration transmission of refrigerant pipeline in building structure. For example:

- When the refrigerant pipeline must be fixed on floor joists or other frames in the structure, use isolated hangers.
- When the refrigerant pipeline runs in the column space or closed ceiling, the isolation hanger should also be used.
- When refrigerant lines pass through walls or windowsills, they should be insulated and isolated.
- Isolate the pipeline from all piping systems.
- Try to reduce the number of 90 ° laps.



Comply with national, state and local regulations when isolating the wire group from joists, rafters, walls or other structural elements.

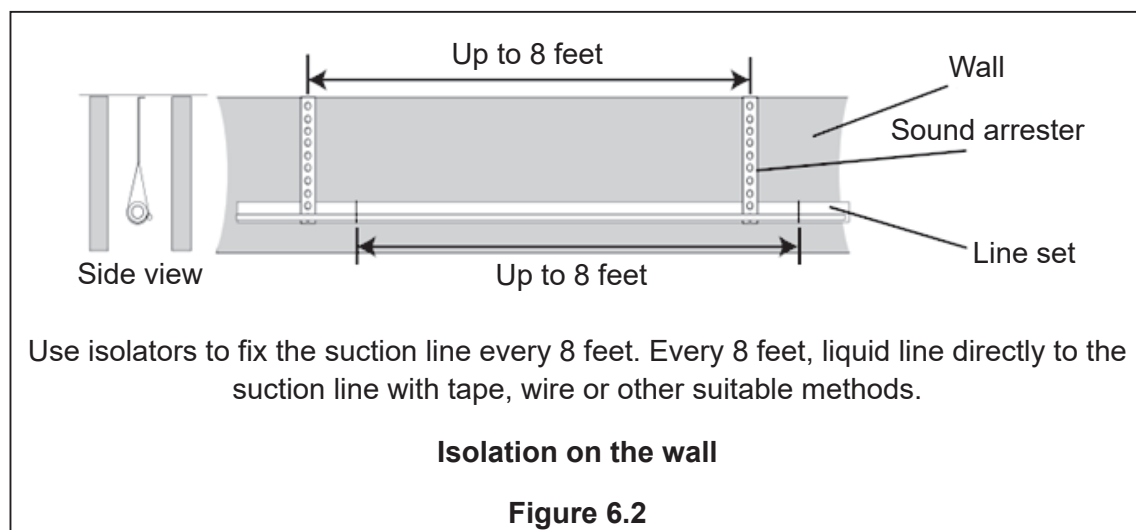
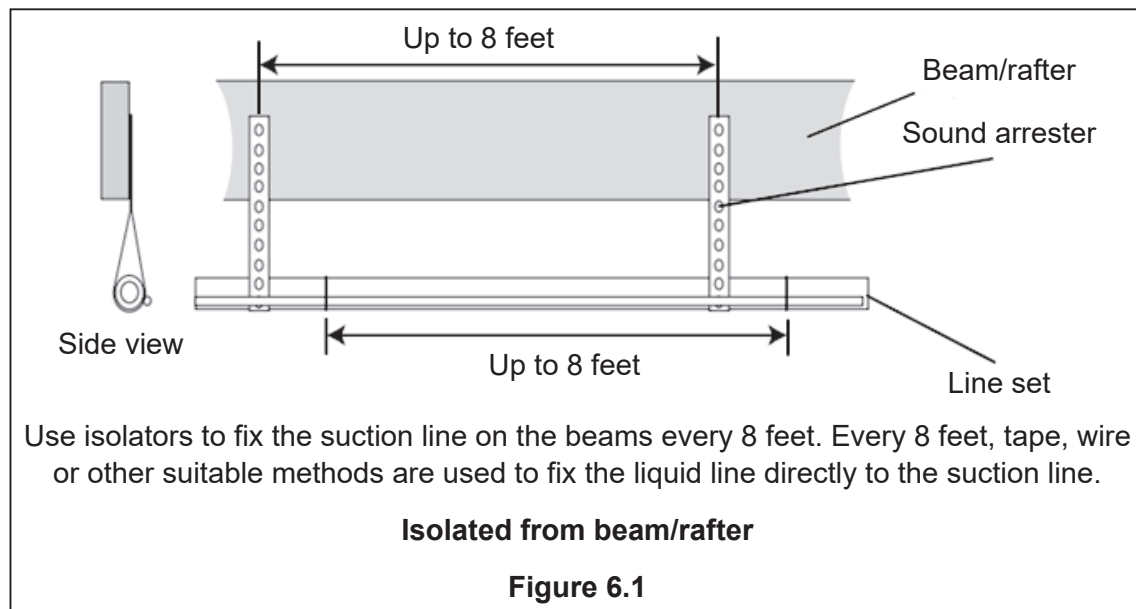

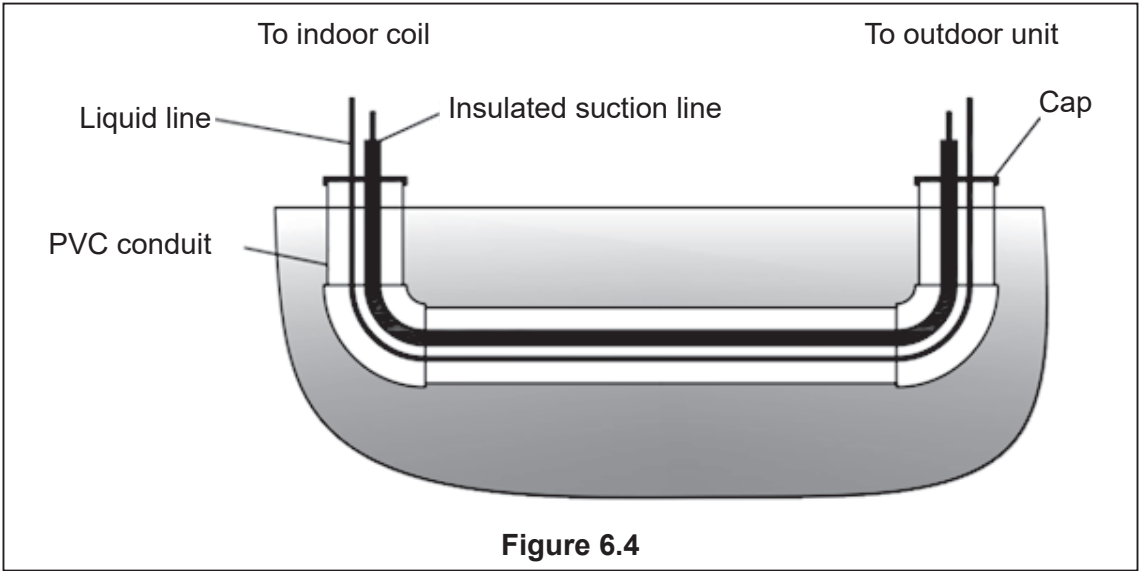
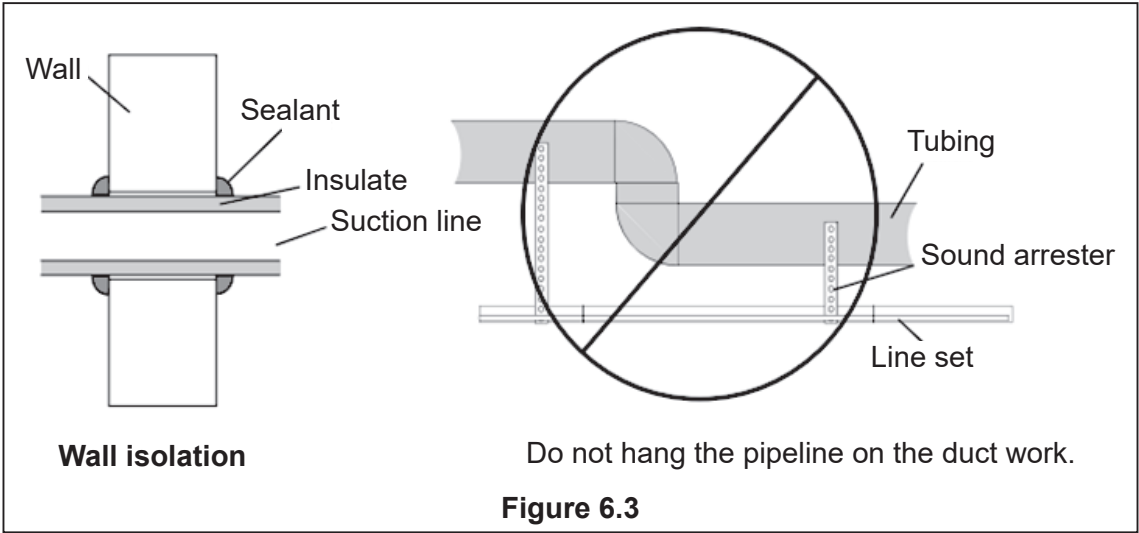

7. Refrigerant Pipeline Brazing

7.1 Brazing Refrigerant Pipeline

1. Remove the cover or plug. Use the deburring tool to deburr the pipe end. Clean the inner and outer surfaces of the pipeline with emery cloth.

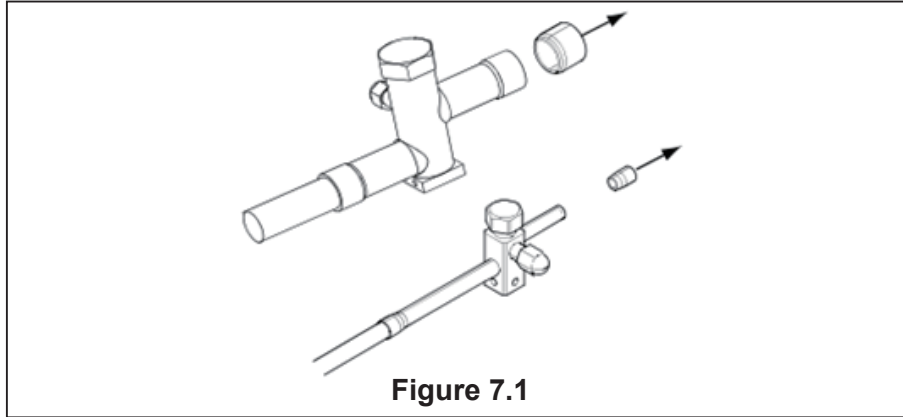

2. Remove the pressure taps from the two service valves.

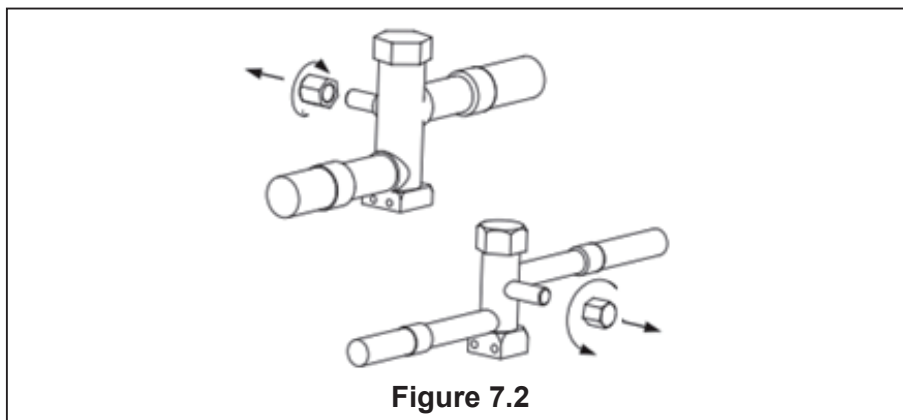

3. Purge refrigerant lines and indoor coils with dry nitrogen.

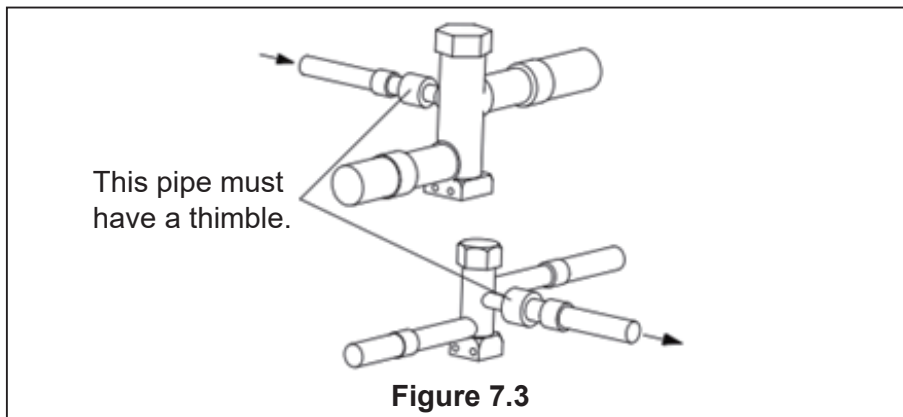

4. Wrap the valve body with a wet rag to avoid thermal damage, and continue the dry nitrogen purging (Figure 16).

Braze the refrigerant line to the service valve.

Braze the filter dryer to the liquid pipe.



All units are recommended to install bidirectional drying filters. Braze the drying filter to the liquid pipe, taking care not to push the refrigerant pipe too hard through the stopper in the drying filter (this may damage the dryer).

Continue the dry nitrogen purge. Don't take off the wet rag before all brazing is completed.



Before stopping the dry nitrogen purge, please remove the wet rag.

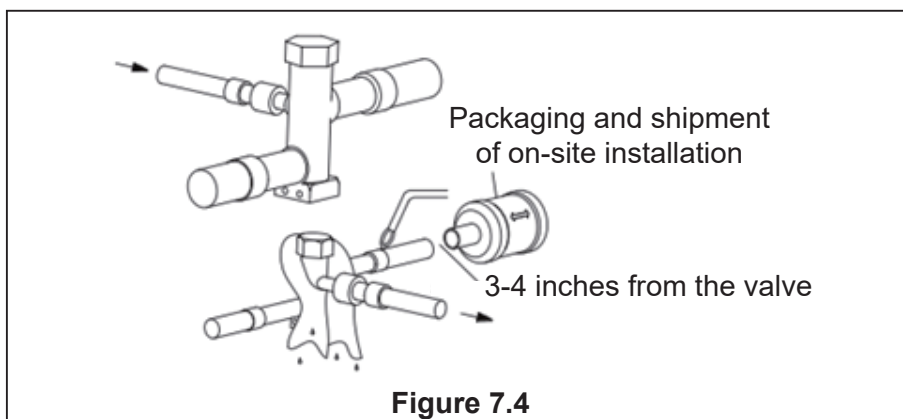

5. After the service valve cools down, replace the pressure tap.

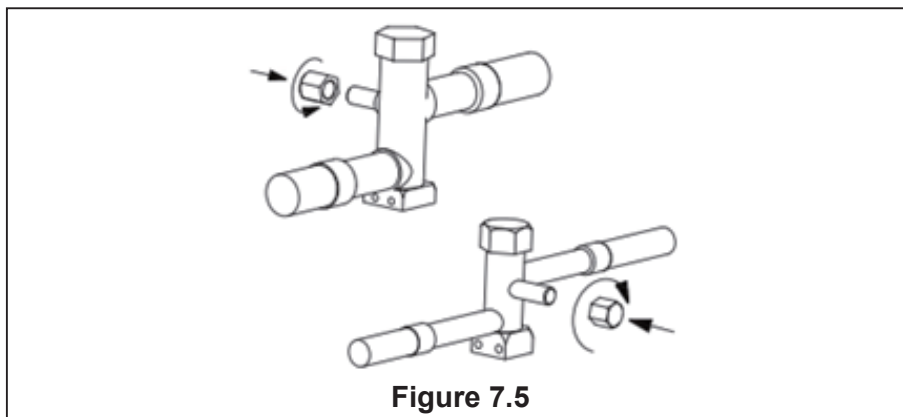

8. Refrigerant Pipeline Leakage Inspection

8.1 Check for Leaks

1. Use dry nitrogen to pressurize the refrigerant line and evaporator coil to 150 PSIG.

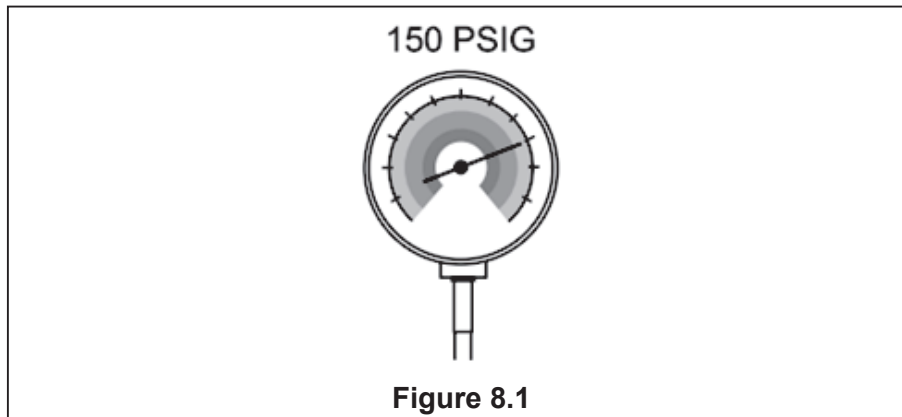

2. Use soap water or foam at each soldering position to check for leaks.

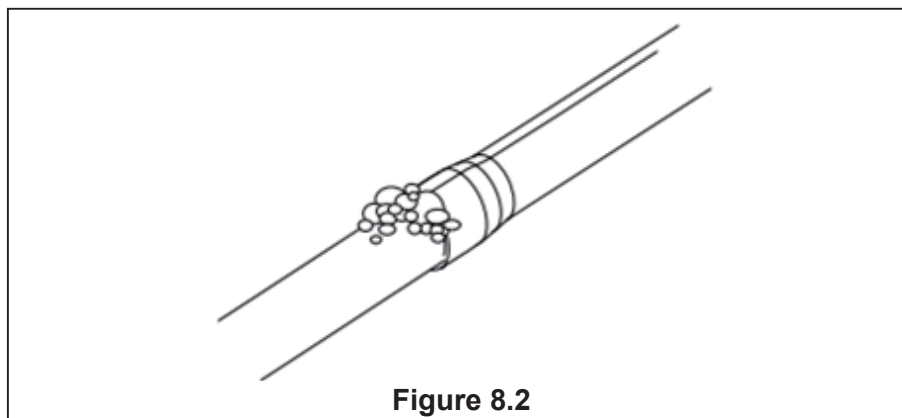

9. Evacuation

9.1 Evacuate Refrigerant Pipeline and Indoor Coil



Do not open the service valve until the leakage inspection and emptying of refrigerant lines and indoor coils are completed.

1. Evacuate until the micrometer reading is not higher than 350 micrometers, and then close the valve of the vacuum pump.

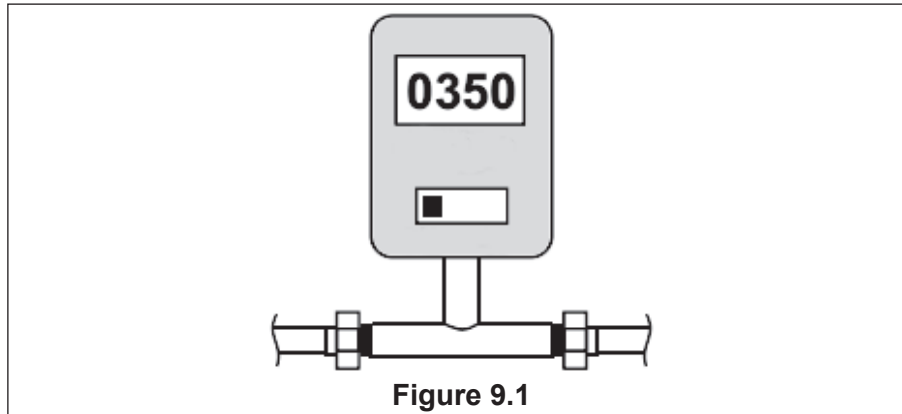

2. Observe micrometer gauge. If the micrometer meter does not rise above 500 micrometers within one (1) minute, the evacuation is completed.

After the evacuation, turn off the vacuum pump and micrometer, and close the valve on the manifold instrument cluster.

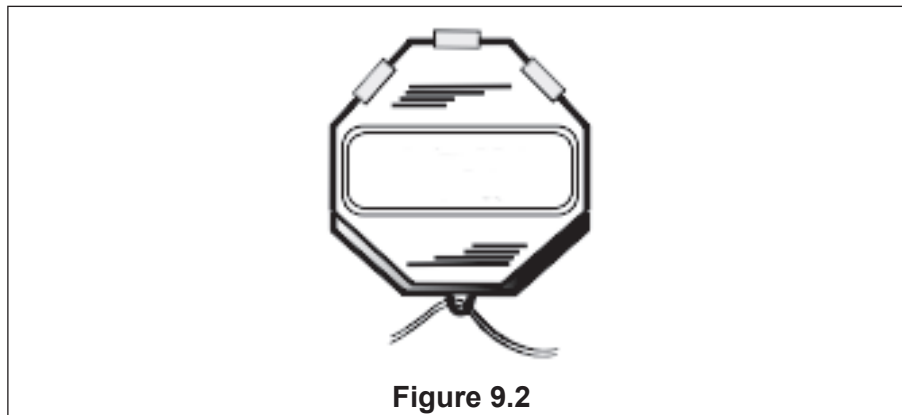

10. Service Valve

10.1 Open the Service Valve

Warning: Moderate to severe burns



- When opening the liquid side service valve, be extra careful. Turn counterclockwise until the valve stem just touches the hem. No torque is required. Failure to observe this warning will result in sudden release of system pressure, and may result in personal injury and/or property damage.



Before opening the service valve, the leakage inspection and emptying must be completed. The valve of copper welded pipe installation should be used for leakage inspection and vacuum pumping. The use of a separate suction port in this process will lead to refrigerant loss.



Before opening the Liquid side service valve, the gas side service valve must be opened first.

1. Remove the valve cover (Figure 10.1).
2. Insert the hex wrench into the valve stem completely and back out counterclockwise until the valve stem just touches the bead (about five (5) turns.)
3. Replace the valve stem cap to prevent leakage. Tighten it with your fingers and turn it for another 1/6 turn.
4. Repeat steps 1-3 for the liquid side service valve.

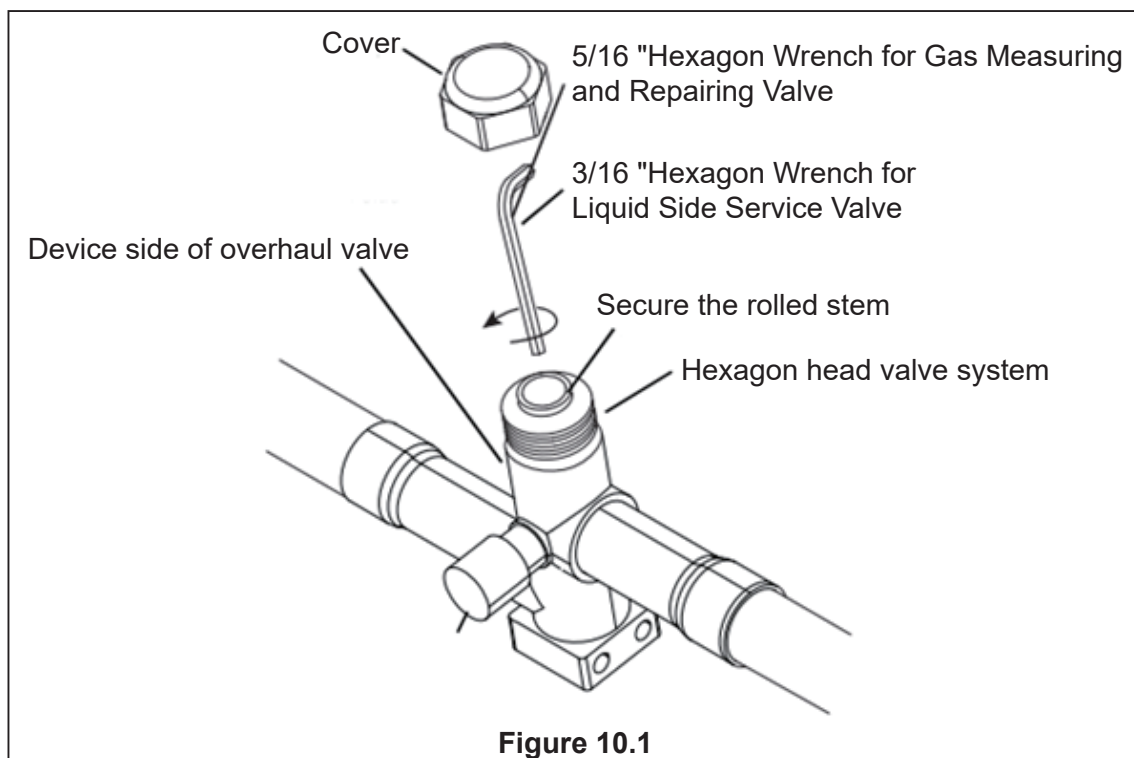

11. Electrical-Low Voltage

11.1 Low Voltage Connection Diagram

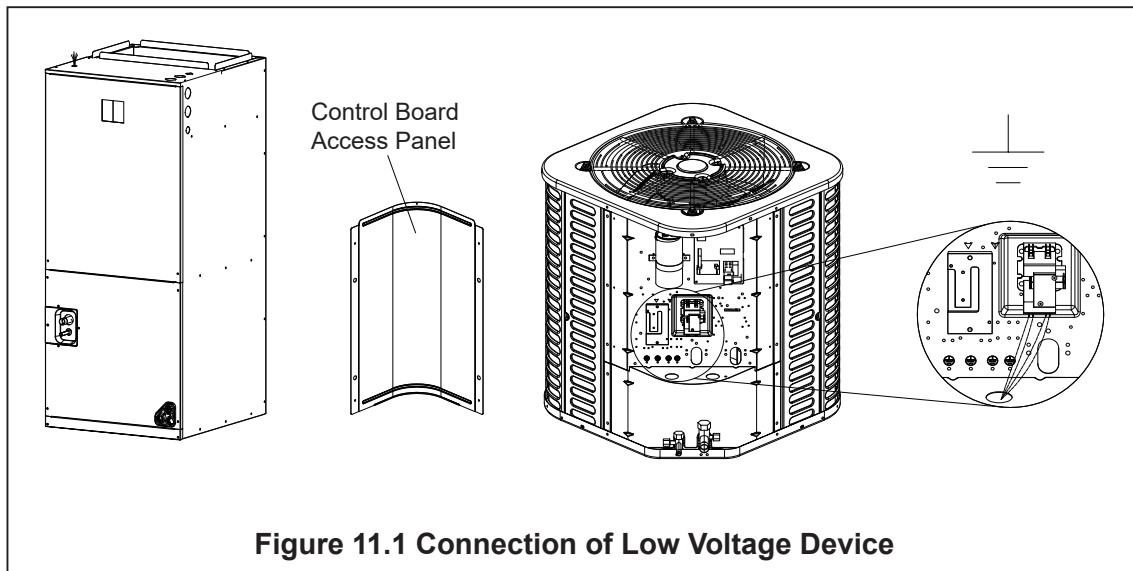

NOTE: The reference figure shows the selection of the low voltage wire hole of the 60K model, and the selection of the wire hole of other models should be made according to the national, state and local regulations.

The wires at the high and low voltage sides need to use different wire holes.

11.2 Wiring Diagram of Thermostat

- Ensure that the power supply is consistent with the rating label of the unit.
- The power connection and grounding of the unit must comply with local regulations.
- 22 AWG is the smallest conductor of the Low-voltage wiring.
- "-----"On-site installation of electrical auxiliary thermal connection
- Single-stage electric auxiliary heating supported by 2H thermostat
- Two-stage electric auxiliary heating supported by 3H thermostat
- W1: The first stage of electric auxiliary heating installed in the indoor unit.
- W2: The second stage of electric auxiliary heating installed in the indoor unit.
- The W signal of the outdoor unit is connected to the electric auxiliary heating or the first-stage electric auxiliary heat.
- The reference figure shows the selection of the low voltage wire hole of the 60K model, and the selection of the wire hole of other models should be made according to the national, state and local regulations.
- The wires at the high and low voltage sides need to use different wire holes.



The dotted line in the following thermostat wiring diagram indicates optional wiring (wiring for passive dehumidification and/or electric heating). For the wiring of the thermostat, please refer to the user manual of the thermostat.



Terminal B will be connected with the thermostat (O/B) wiring. The reversing valve is energized during heating.

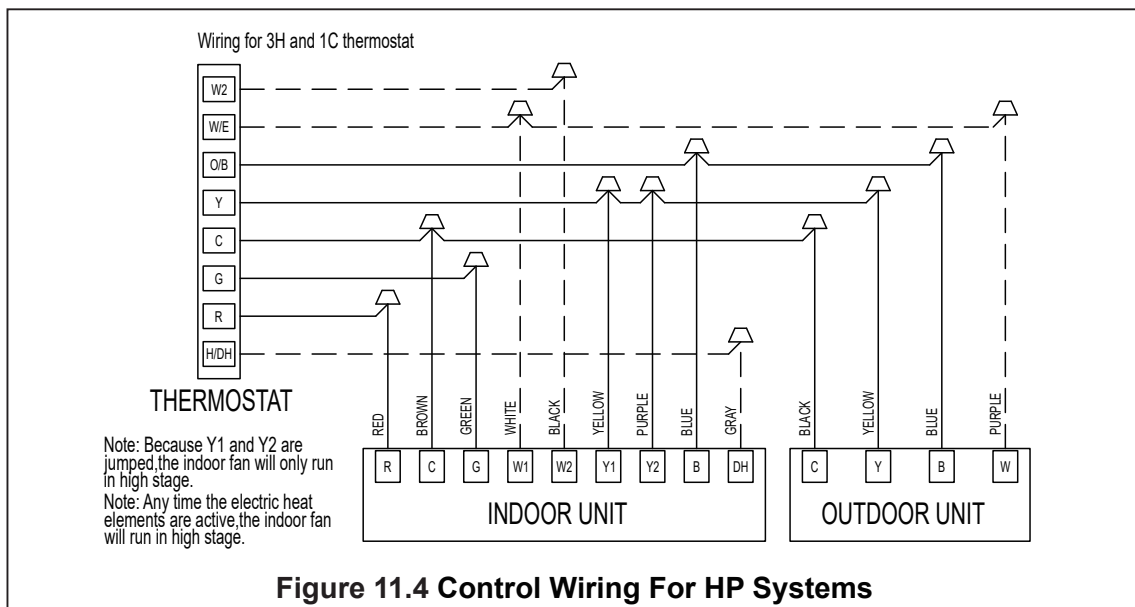
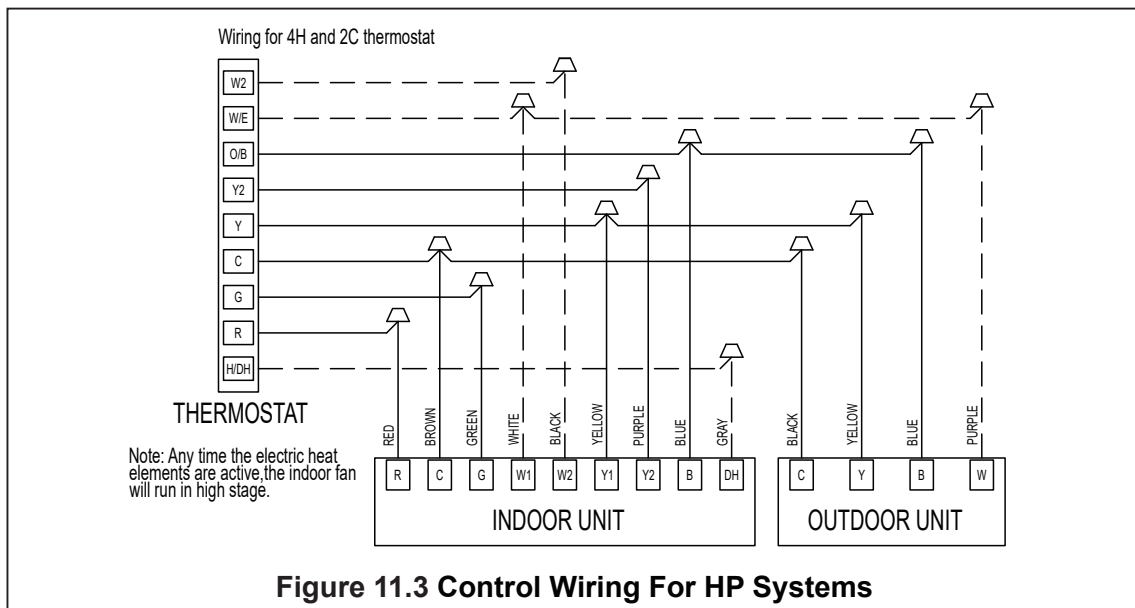
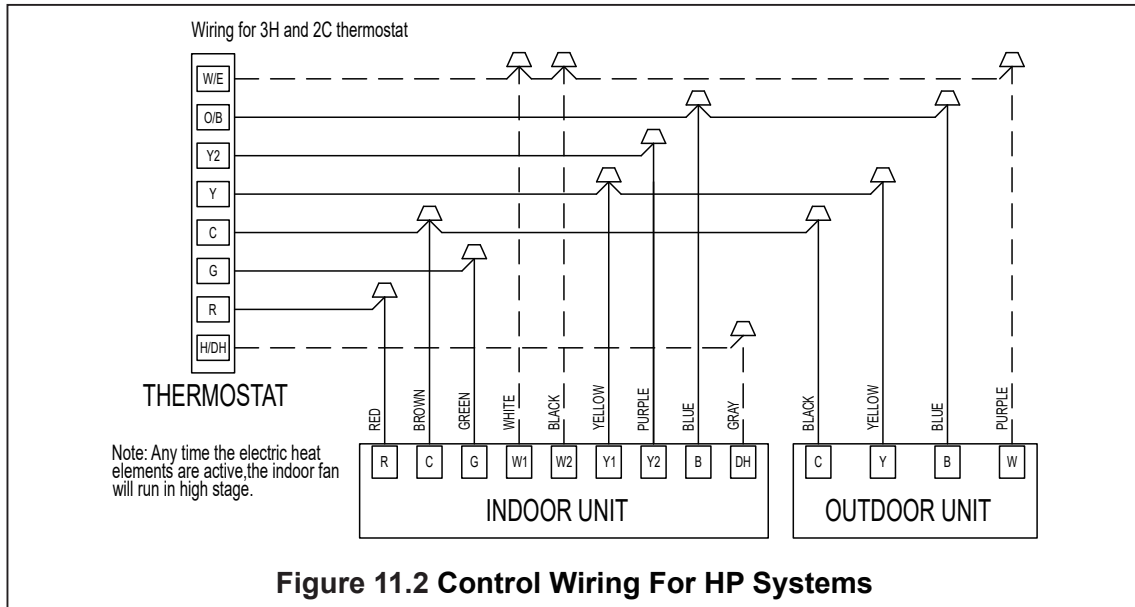

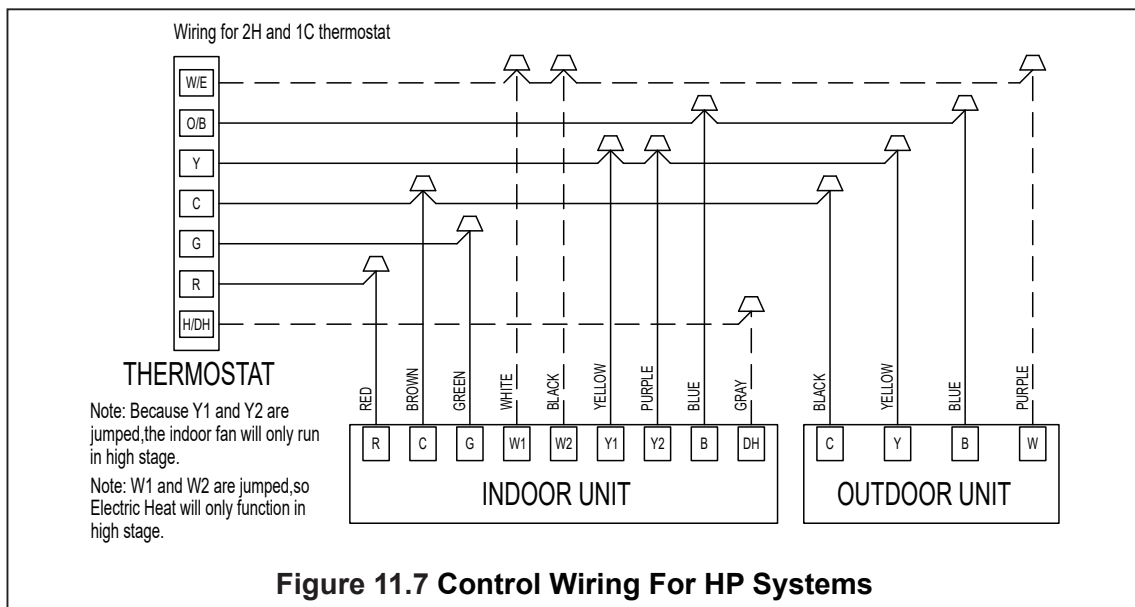
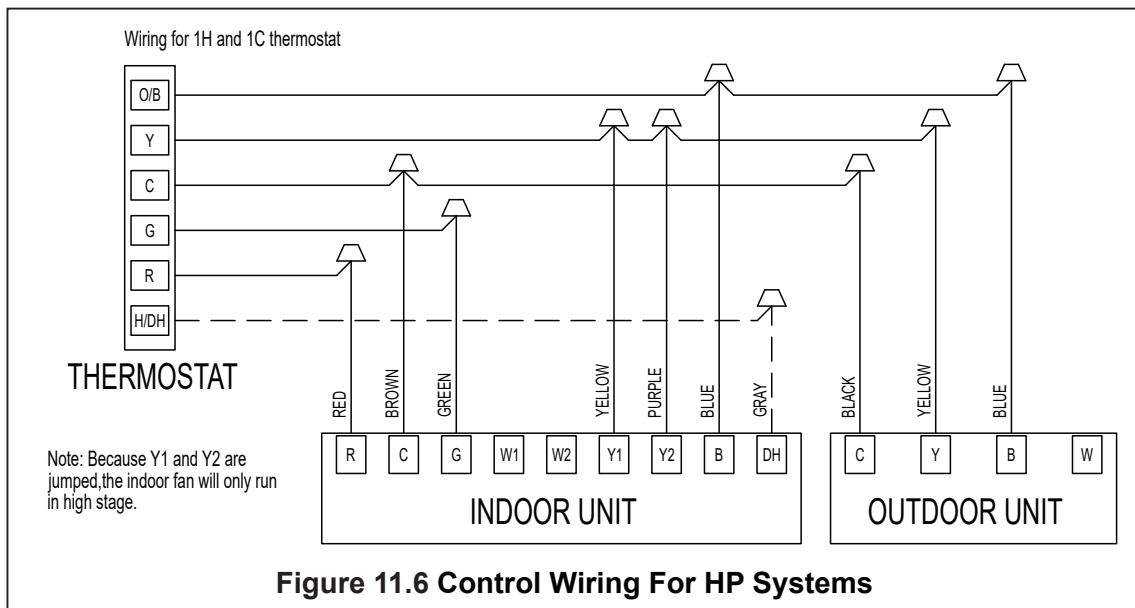
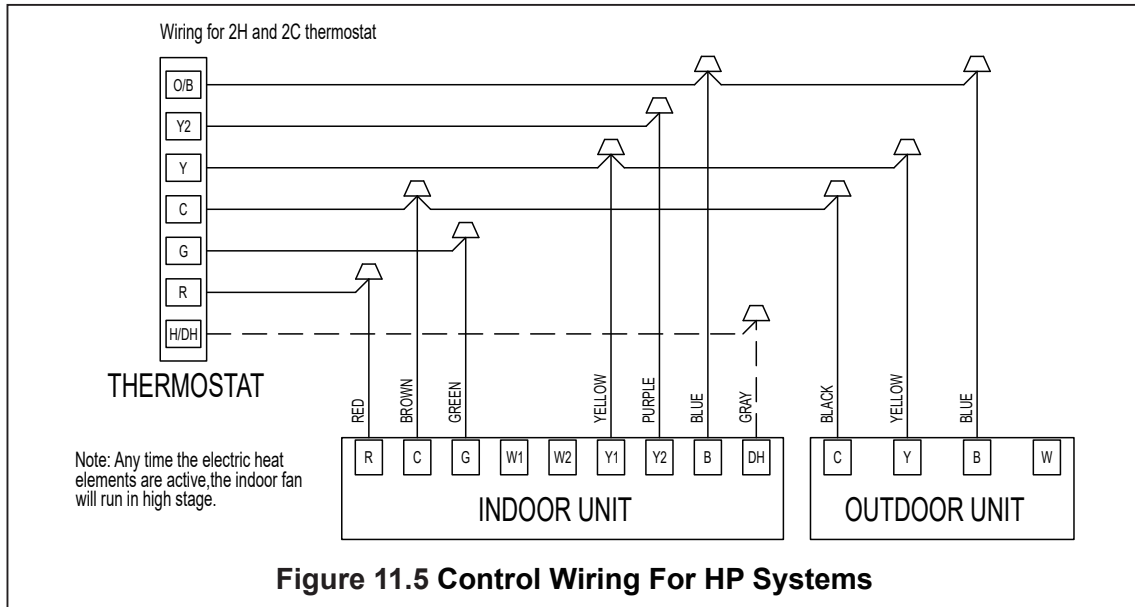

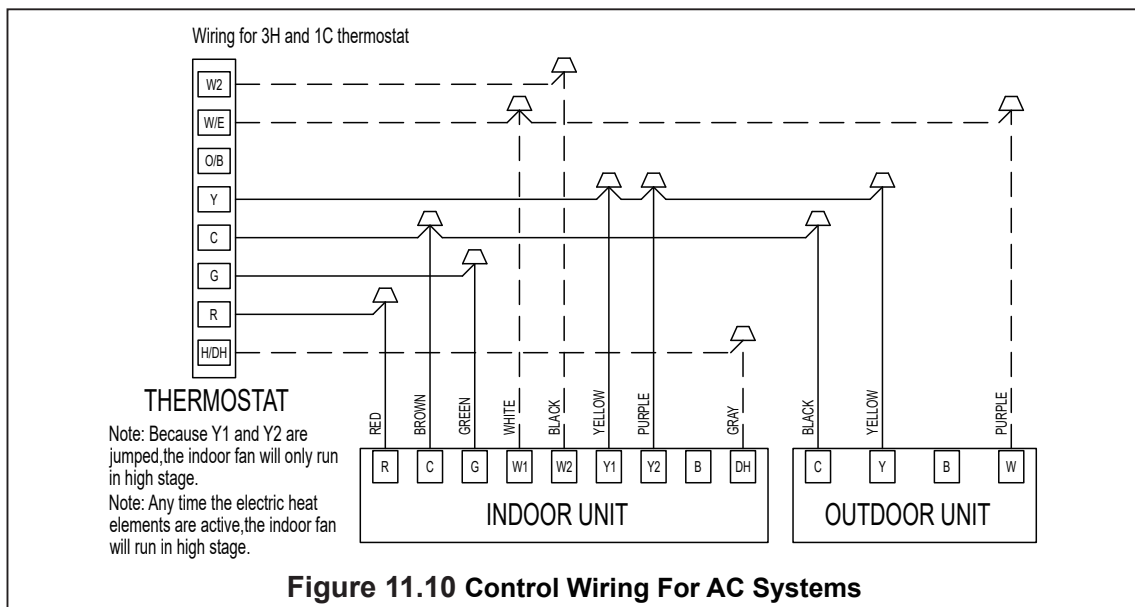
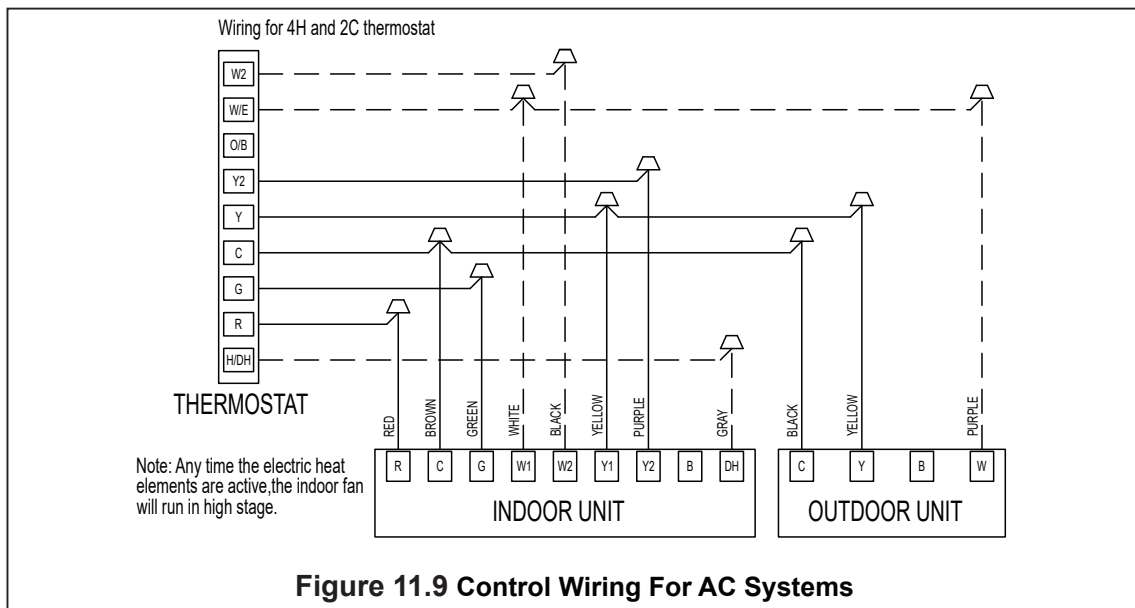
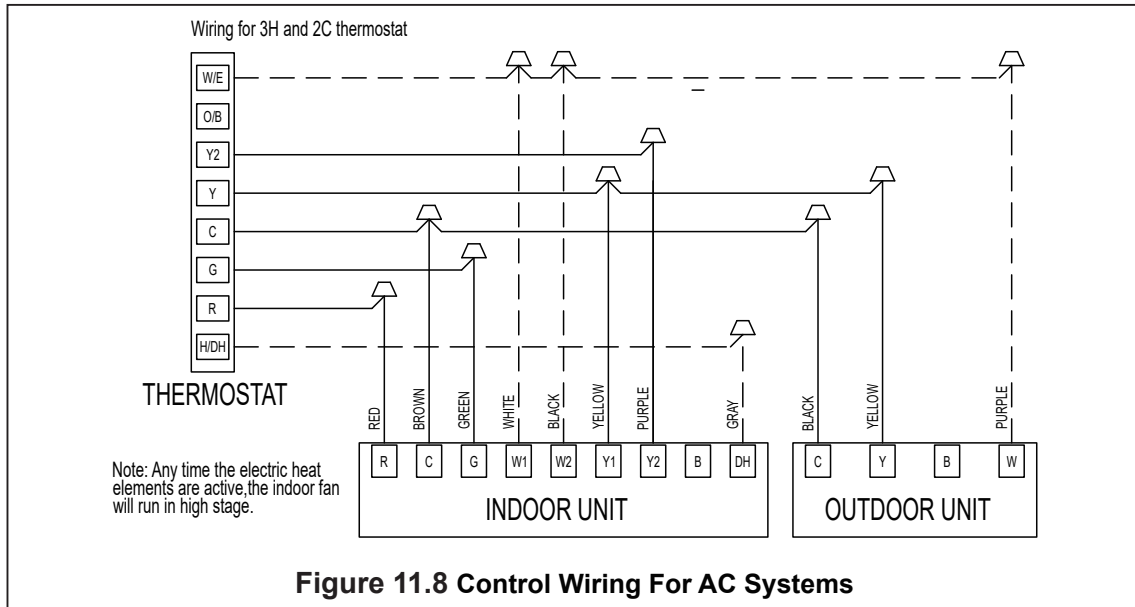

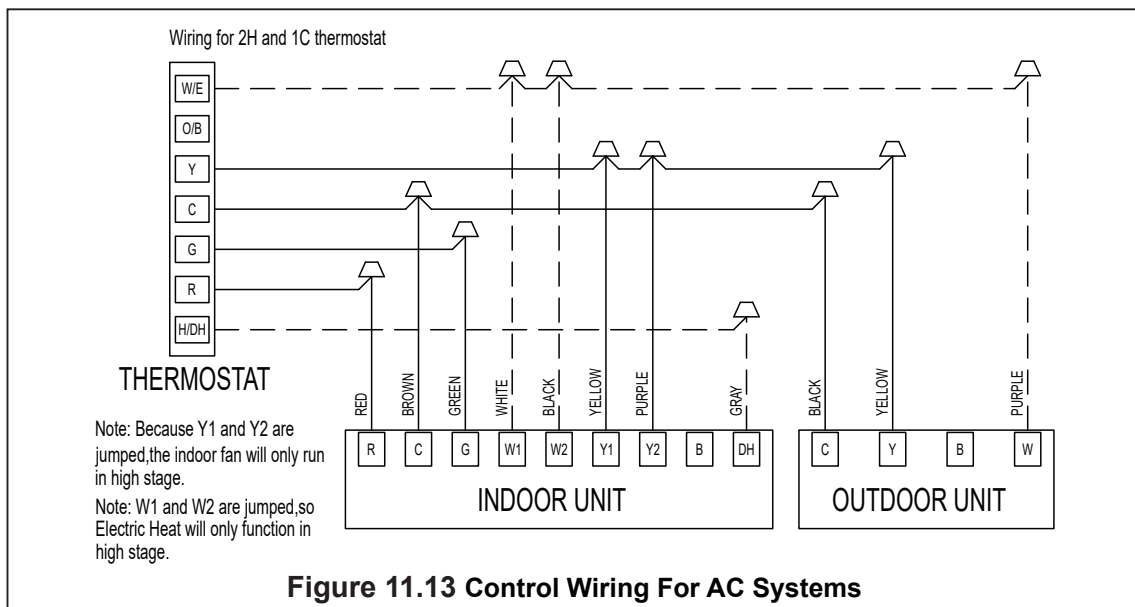
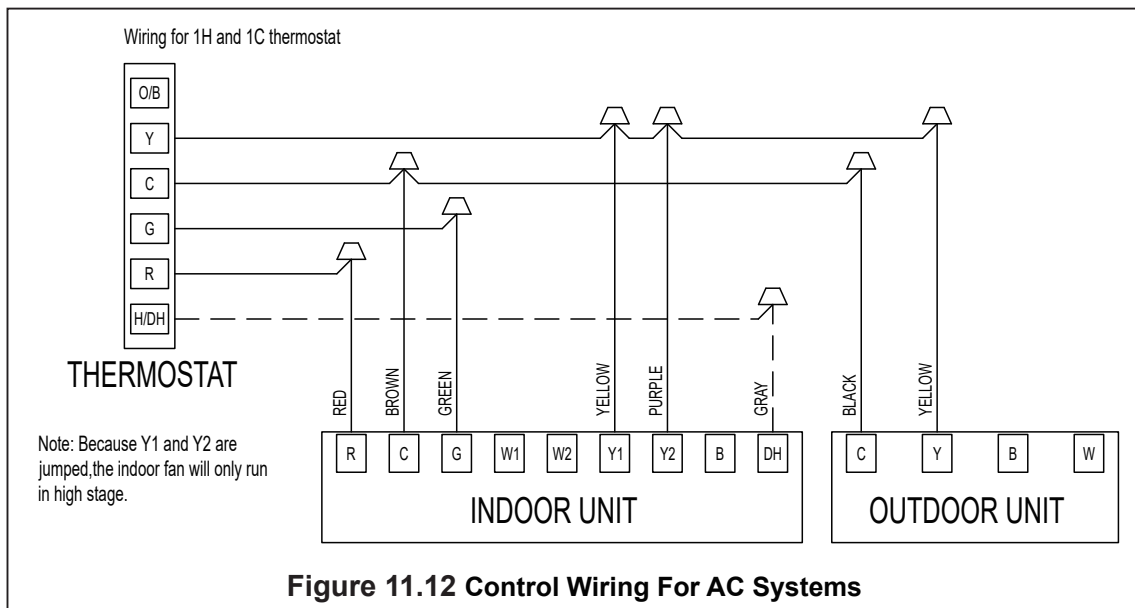
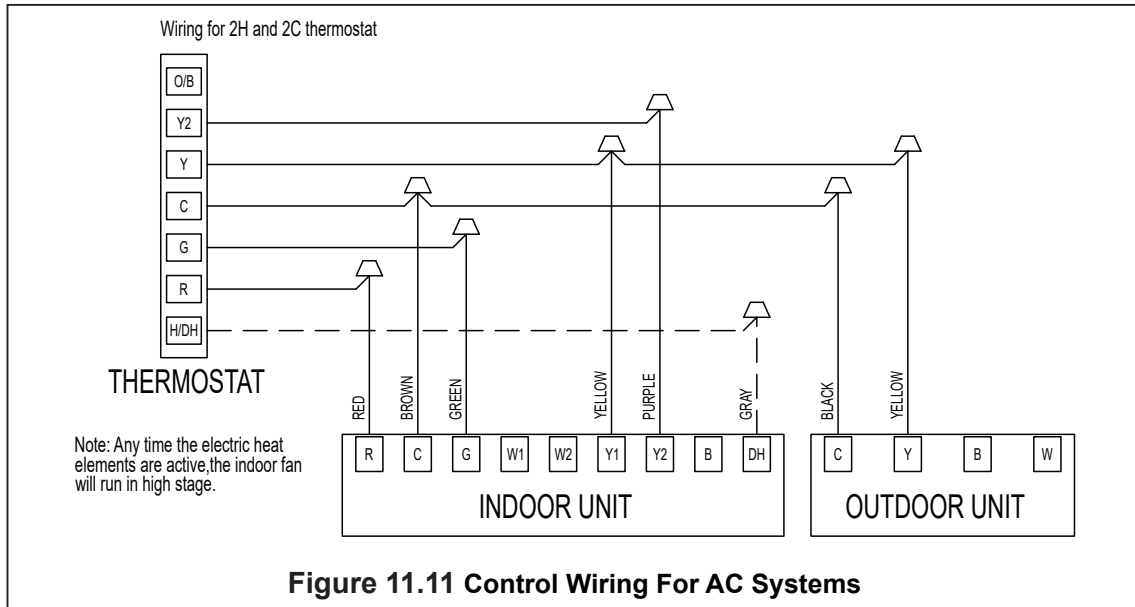

12. Electrical-High Voltage

12.1 High Voltage Power Supply



Warning: Live electrical parts!

- During the installation, testing, maintenance and troubleshooting of this product, it may be necessary to use live electrical parts. Failure to observe all electrical safety precautions when exposed to live electrical parts may result in death or serious injury.

The high-voltage power supply must match the nameplate of the unit (208/230V, 1PH, 60Hz).



Power supply wiring must comply with national, state and local regulations.

Follow the instructions of the unit wiring diagram located inside the access panel of the control box, and refer to the wiring diagram in this installation instruction.

12.2 High Voltage Isolating Switch

Install a separate disconnect switch on the outdoor unit.

High-voltage wiring must use flexible electrical conduit supplied on site.

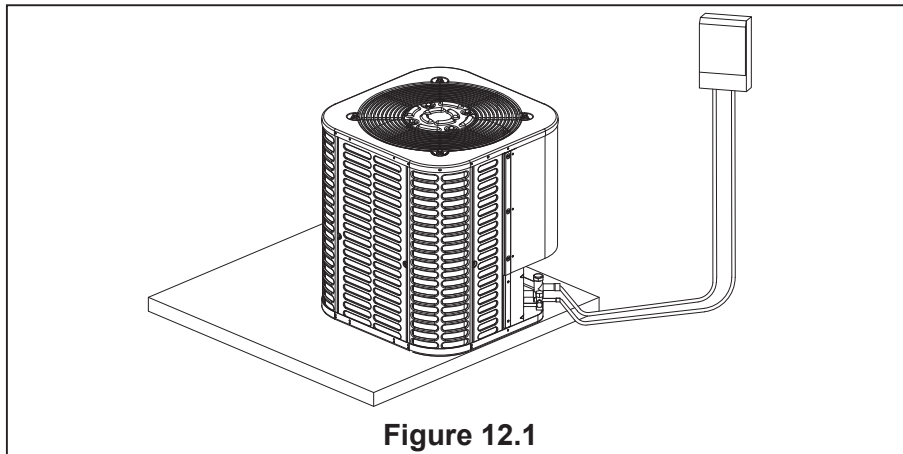

Figure 12.1

12.3 High Voltage Grounding

Ground the outdoor unit according to the requirements of national, state and local regulations.

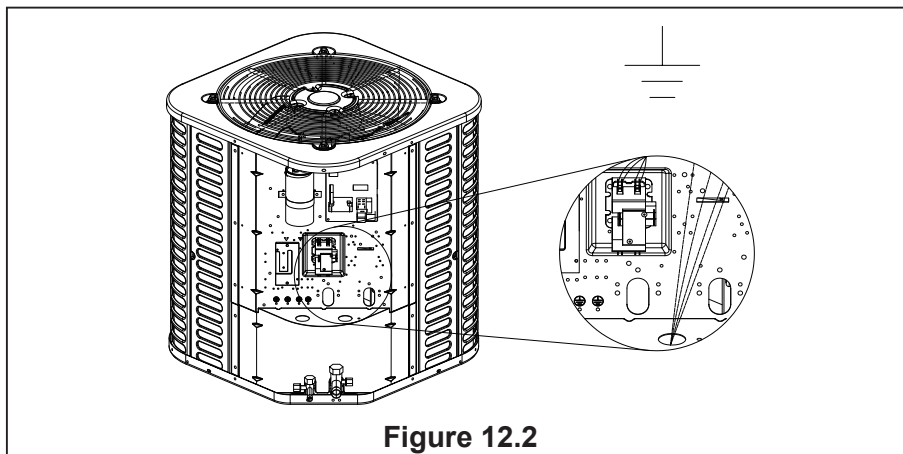

Figure 12.2

NOTE: The reference figure shows the selection of the high voltage wire hole of the 60K model, and the selection of the wire hole of other models should be made according to the national, state and local regulations.

The wires at the high and low voltage sides need to use different wire holes.

13. Start

13.1 System Startup

1. Make sure that parts 7, 8, 9, 10, 11 and 12 have been completed.
2. Set the system thermostat to off.

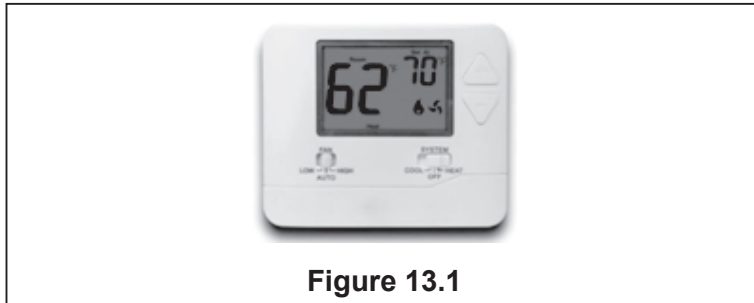

Figure 13.1

3. Turn on the disconnect switch and turn on the power of the indoor unit and outdoor unit.

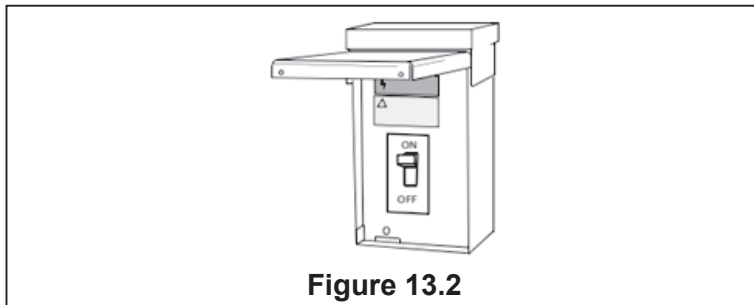

Figure 13.2

4. Set the system thermostat to ON.

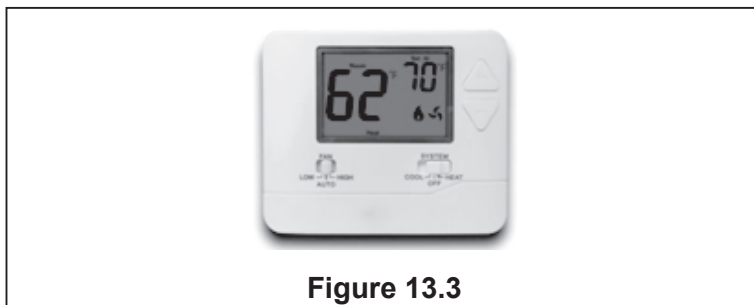

Figure 13.3

14. System Refrigerant Charging Regulation

14.1 Charging: Weigh-In Method

During the initial installation, or when the refrigerant quantity of the updated system is charged, the weigh-in method is used. When there is no power supply at the site of the unit or the operating conditions (indoor/outdoor temperature) are not within the range verified by Subcooling charging method. All models have a charge factor of 0.6 oz / ft for refrigerant pipe length.



For a 25-ft standard size interconnecting liquid pipe, the factory refrigerant charge of the outdoor unit is sufficient.

New installation-Calculate the charging amount of connecting pipes larger than 25 ft.

1. Total length of pipeline (ft) = _____(a)
2. Standard piping setup (ft) =25 (b)
3. (a) minus (b) = _____ (c)
4. Refrigerant multiplier = 0.6 oz/ft (d)
5. Additional refrigerant quantity (c*d) = _____(e)*

* If the line set is less than 25 feet, e=0

Closed system maintenance-calculate the total filling amount of the system.

1. Total length of pipeline (ft) = _____(a)
2. Standard piping setup (ft) =25 (b)
3. (a) minus (b) = _____ (c)
4. Refrigerant multiplier = 0.6 oz/ft (d)
5. Additional refrigerant quantity (c*d)= _____(e) *
6. Factory filling quantity (nameplate)= _____(f)
7. Total system charge (e +f) = _____

* If the line set is less than 25 feet, e =0



The only mode approved for verifying system charging is in "forced cooling mode". The outdoor temperature must be between 55°F and 120°F, and the indoor temperature should be between 70°F and 80°F.

14.2 Subcooling Charging and Refrigerant Quantity Adjustment in Cooling Mode

1. Check the outdoor ambient temperature.

Subcooling (cooling mode) is the only recommended charging method when the outdoor ambient temperature is higher than 55°F.

For outdoor ambient temperature below 55°F, use the weigh-in charging method.



When the outdoor ambient temperature is higher than 55°F, be sure to return in spring or summer, so as to accurately charge the system in cooling mode.

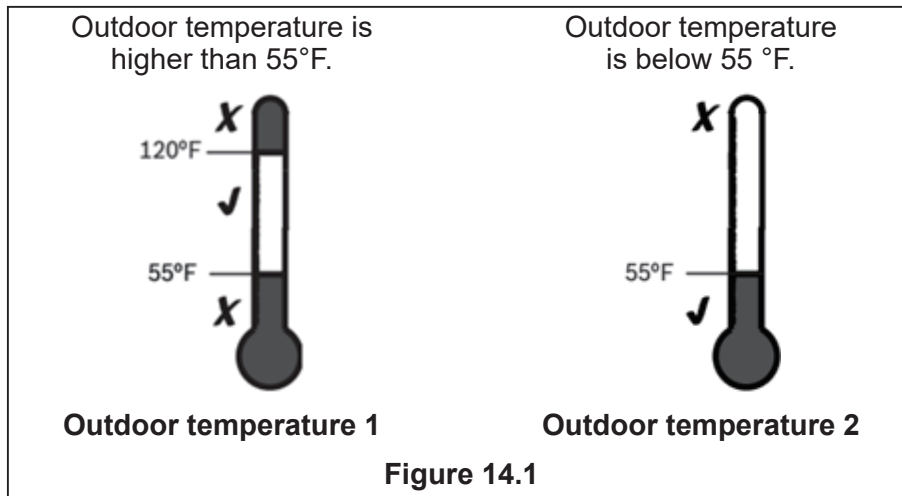

For best results, the indoor temperature should be kept between 70°F and 80°F during installation.

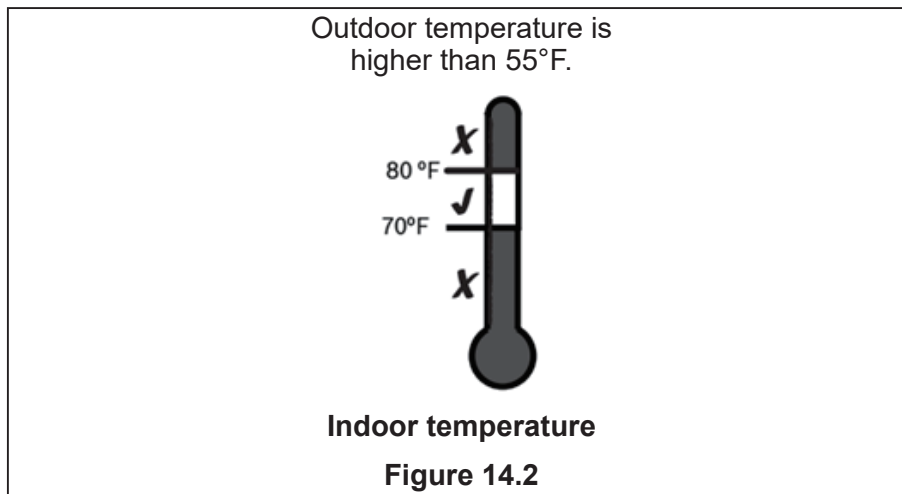

2. Make sure that parts 7, 8, 9, 10, 11, 12 and 13 have been completed.

15. System Operation and Troubleshooting

15.1 Control Logic Description

- The system is using universal 24V control.

15.2 Sensors

- T3- Outdoor unit coil temperature(Table 15.3)
- T4- Ambient temperature(Table 15.3)
- T5- Compressor exhaust temperature(Table 15.4)
- TH- Compressor suction temperature(Table 15.3)
- HP- High pressure switch
- LP- Low pressure switch

15.3 Description of Defrosting

- Outdoor unit W terminal will output 24V signal during defrost mode.
- Unit will run defrost mode in below condition:
 - 1) Unit run in heating mode
 - 2) Compressor is running.
 - 3) The defrost mode and cycle time is relate with SW1-1 dip switch.

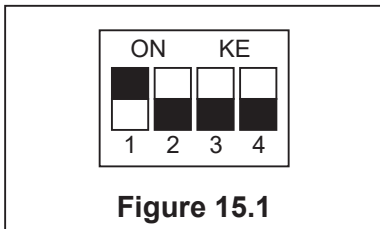

Table 15.1

Dial switch	SW1-1
ON	Timed defrost (40 mins)
OFF	Automatic Defrost

- ① When SW1-1 is OFF, unit will run defrost Automatic Defrost when it meets any below conditions:

Condition 1: When compressor start, unit will record minimum T3 which named T3_o, and minimum T4 which named T4_o during compress start 10-15 mins.

When outdoor unit meets below condition, unit will run defrost mode:

 - a) When T3<32°F, and compressor run for 40mins;
 - b) Unit calculate $\Delta T4=T4-T4_o$ (If $\Delta T4 \leq 3.6^\circ F$, unit will result $\Delta T4=0^\circ F$), and $T3 + 3.6^\circ F < (T3_o + \Delta T4)$ keep 30s.

Condition 2: When T3<32°F, and compressor run for 40 mins, and T3<5°F, unit will defrost.
- ② When SW1-1 is ON, unit will run defrost Timed defrost (40 mins) when it meets any below conditions:

Condition 1:
Compressor is running, when T3<30.2°F and keep 40 mins, unit will run defrost.

Condition 2:
When unit power on, and compressor first time start, and T3<28.4°F, unit will run defrost.

Condition 3:
Condition 2: When unit standby for 2 hours, and T3<28.4°F, unit will run defrost.
- 4) Quit defrost condition:
 - ① When SW1-1 is OFF, unit will quit defrost when it meets any below condition.

Condition 1: Defrosting time lasts for 10 mins.

Condition 2: T3≥ 50°F
 - ② When SW1-1 is ON, unit will quit defrost when it meets any below condition.

Condition 1: Defrosting time lasts for 10 mins.

Condition 2: T4≥28.4°F and T3≥77°F

Condition 3: Compressor stop

Condition 4: T4<28.4°F, T3≥77°F and keep 60s.

15.4 Crankshaft heater control function (optional)

In the case of low outdoor temperatures, the refrigerant migrates to the compressor, noise and bearing scouring are generated at start-up, All CCHs must be installed in the lower half of the compressor housing. Its purpose is to heat the compressor in standby, allow the refrigerant to flow out of the compressor. In the long cold weather, extend downtime and power up CCH.

The control of the crankshaft heater is affected by the dip switch. When SW1-2 is ON, the machine is in high drop mode. When SW1-2 is OFF, the machine is in regular drop mode. The control of the crankshaft heater is carried out according to the following logic.

① Crankshaft heater start conditions:

One of the following conditions is met, to turn on the crankshaft heater:

Condition 1: The following three conditions are met at the same time:

- a) $T5 < 73.4^{\circ}\text{F}$.
- b) The machine is currently in standby, and $T4$ has been below 68°F .
- c) Machine downtime $\geq 1\text{h}$.

Condition 2: The compressor is not turned on during the initial power on, if $T5 < 73.4^{\circ}\text{F}$ and last for 30 seconds, then crankshaft heater will be turned on. In the meantime, if SW1-2 is selected, then unit will be in the high vertical preheating mode.

Condition 3: In defrost mode and $T5 < 73.4^{\circ}\text{F}$.

② Crankshaft heater stop conditions:

When the machine enters the high drop preheating function:

The crankshaft heater needs to be continuously opened for 4 hours to warm up. During warm-up, only the cooling mode medium voltage can be started. Meet the continuous warm-up for 4 hours, or the machine is in refrigeration mode after the medium press has been running continuously for more than 10 minutes. If $T5 \geq 82.4^{\circ}\text{F}$, close the crankshaft heater.

When the machine does not enter the high drop warm-up function:

At $T5 \geq 82.4^{\circ}\text{F}$, turn off the crankshaft heater.

15.5 Four-way valve operate condition

Four-way valve will power on in heating mode, and power off in cooling mode.

15.6 Anti-freeze protection: effective only in cooling mode

Compressor suction temperature is less than 32°F , compressor will be stopped, Compressor suction temperature is greater than 46.4°F , or the length of the shutdown reached 6 mins, compressor will be started (minimum start interval of 5 mins).

15.7 Anti-high temperature protection: effective only in heating mode

High temperature protection (will be effective in heat pump mode)

If discharge temperature is over 179.6°F , and fan motor is turned on over 3 mins, then outdoor fan motor will be turned off. If discharge temperature is less than 168.8°F and outdoor fan motor is turned off for maximum 6 mins, then outdoor fan motor will be turned on again.

If outdoor fan motor is turned off, and discharge temperature is more than 221°F and lasted for 2 mins, then it can be judged that the system is severely lack of refrigerant, which will lead to unit shutdown.

15.8 LED display function of the outdoor unit main PCB and fault table

Table 15.2

display content:	Content	Discription
Normal display: Yellow light OFF	Green light flash slow	Unit standby
	Green light ON	Unit is running
display content:	T3 temperature sensor error	Yellow light flash 1 time for every 8s
	T4 temperature sensor error	Yellow light flash 2 time for every 8s
	T5 temperature sensor error	Yellow light flash 3 time for every 8s
	Low pressure protection	Yellow light flash 4 time for every 8s
	High pressure protection	Yellow light flash 5 time for every 8s
	T3 high temperature protection	Yellow light flash 6 time for every 8s
	T5 high temperature protection	Yellow light flash 7 time for every 8s
	Fan motor feedback error	Yellow light flash 8 times for every 8s (Only for DC fan motor)
TH temperature sensor error	Yellow light flash 9 times for every 8s	
Outdoor unit error and locked: Green light ON, Yellow light flash.	Low pressure protection occur 6 times within 60 mins.	Yellow light flash 4 times for every 8s
	High pressure protection occur 6 times within 60 mins.	Yellow light flash 5 times for every 8s
	T3 high temperature protection occur 6 times within 60 mins.	Yellow light flash 6 times for every 8s
	T5 high temperature protection occur 3 times within 20 mins.	Yellow light flash 7 times for every 8s
	Fan motor feedback error occur 3 times within 20 mins	Yellow light flash 8 times for every 8s
	Refrigerant leakage protection	Yellow light flash 9 times for every 8s

15.9 Outdoor unit main PCB description

Outdoor unit main PCB

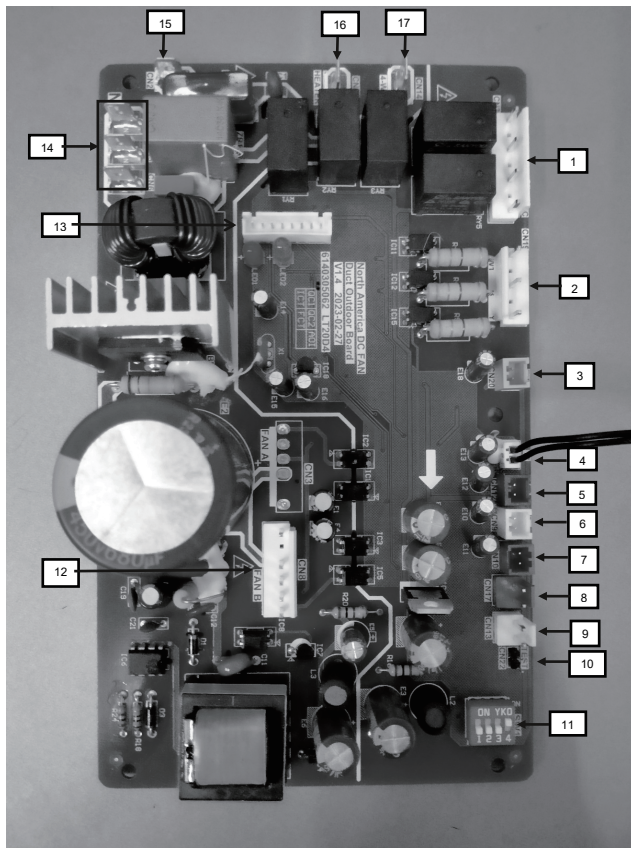

Num	functional description
1	W COMP R C terminal (24V)
2	W1 B Y terminal (24V)
3	TH temperature sensor terminal
4	T3 temperature sensor terminal
5	T4 temperature sensor terminal
6	T5 temperature sensor terminal
7	Reserved
8	Low pressure switch terminal
9	High pressure switch terminal
10	TEST terminal
11	Dial switch
12	DC fan motor terminal
13	DEBUG terminal
14	Power input N terminal
15	Power input L terminal
16	Crankshaft heater terminal
17	Four-way valve terminal

Figure 15.2

15.10 Troubleshooting of Fault Codes



Warning: Dangerous voltage

- When measuring the resistance, make sure that the power of the unit is turned off and wait for 3 minutes before measuring.

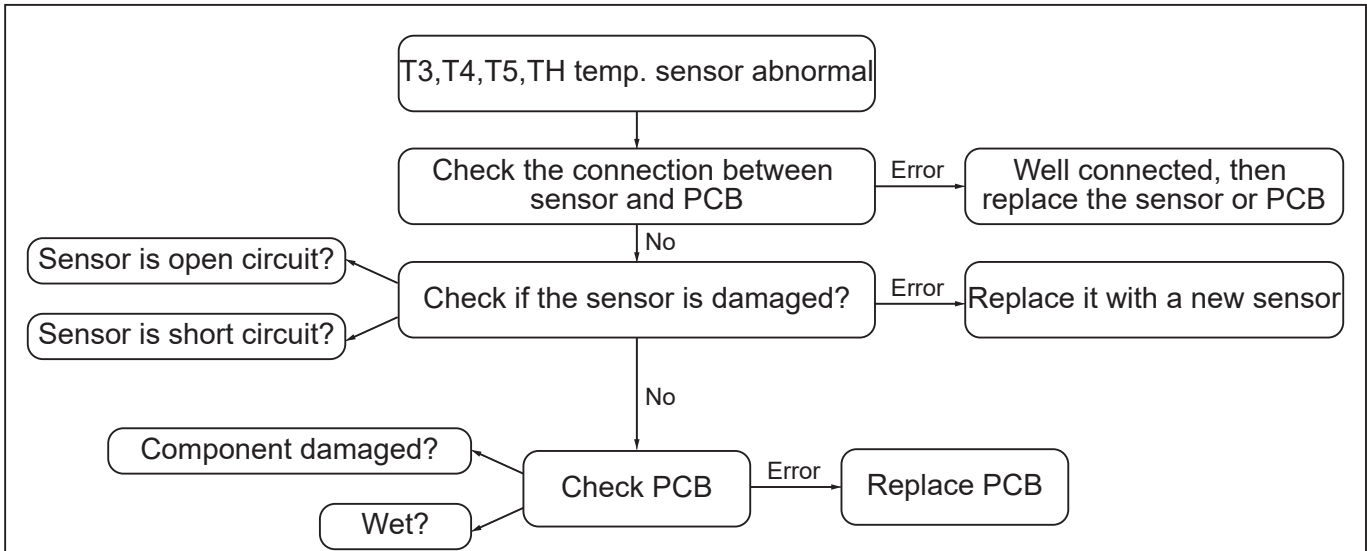

Figure 15.3 T3, T4, T5, TH Temperature sensor error

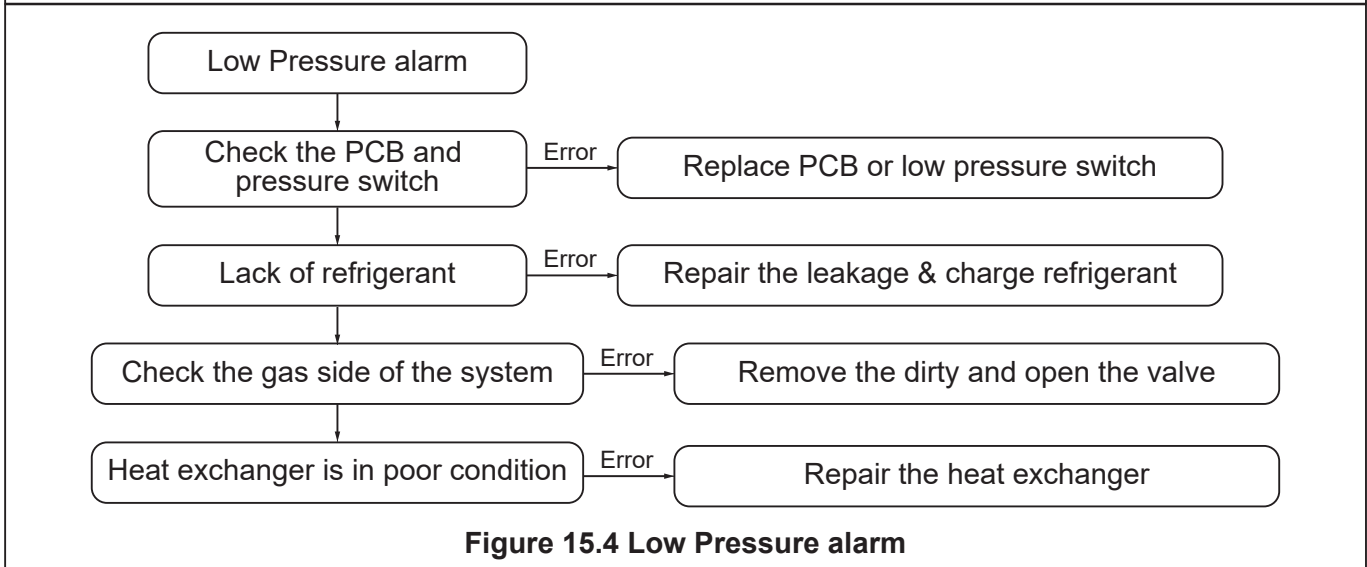

Figure 15.4 Low Pressure alarm

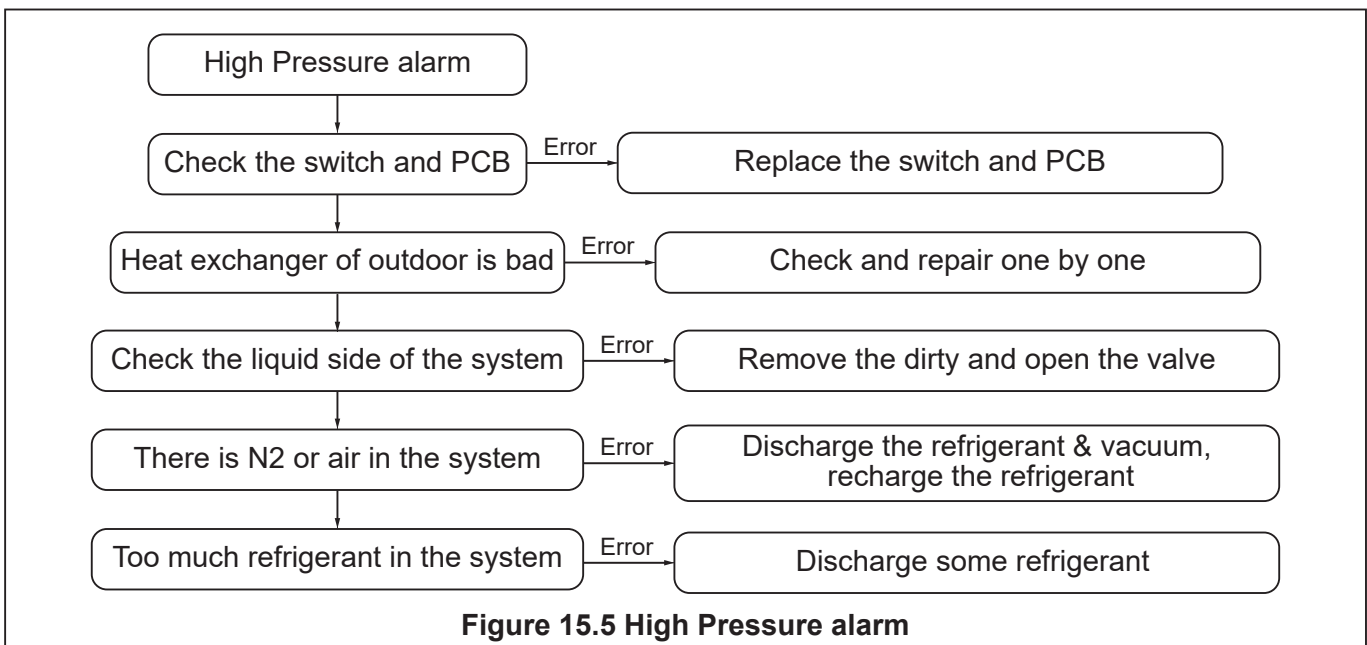

Figure 15.5 High Pressure alarm

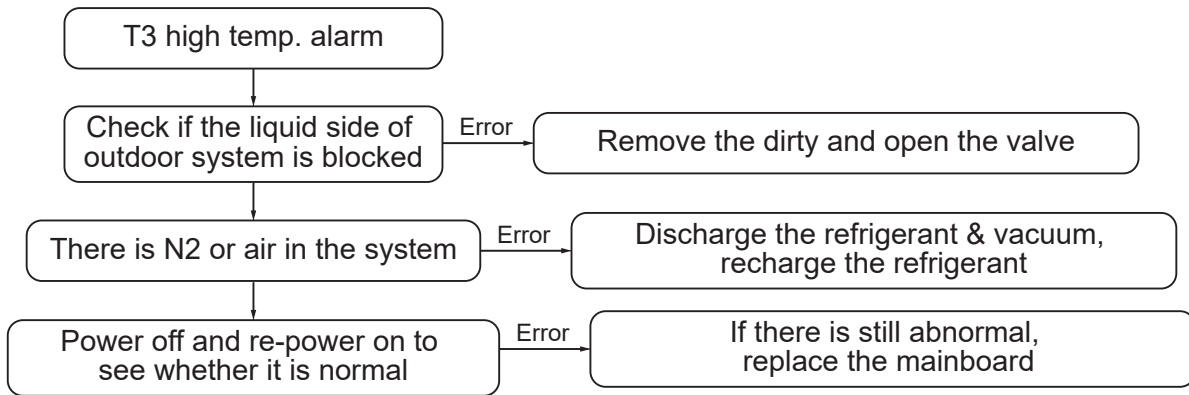

Figure 15.6 T3 high temperature alarm

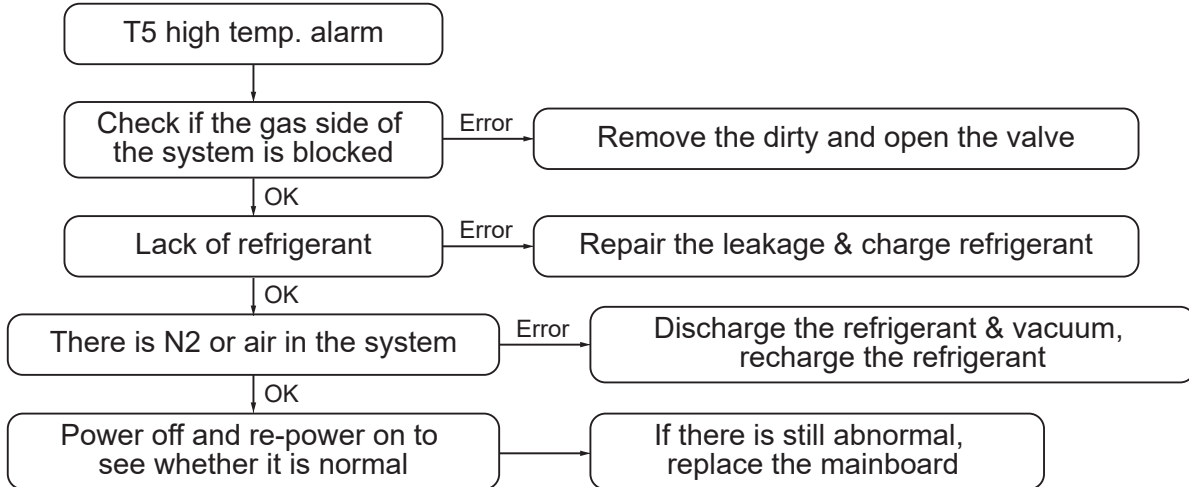

Figure 15.7 T5 high temperature alarm

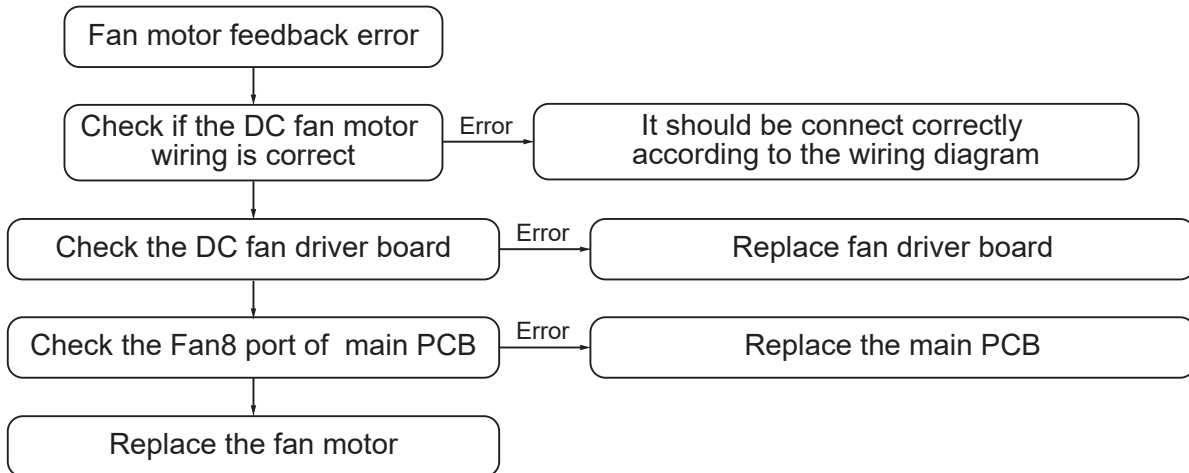

Figure 15.8 Fan motor feedback error

15.11 Temperature-Resistance Relationship Table (For Sensors)

Table 15.3 for T3, T4, TH

Temperature F	Temperature C	Electric resistance kΩ	Volt DC	Temperature F	Temperature C	Electric resistance kΩ	Volt DC
-5	-20.6	33.367	0.57	90	32.2	3.865	2.63
0	-17.8	29.227	0.64	95	35.0	3.508	2.75
5	-15.0	25.657	0.72	100	37.8	3.187	2.87
10	-12.2	22.595	0.80	105	40.6	2.900	2.99
15	-9.4	19.942	0.89	110	43.3	2.652	3.09
20	-6.7	17.697	0.98	115	46.1	2.421	3.20
25	-3.9	15.673	1.08	120	48.9	2.214	3.30
30	-1.1	13.917	1.18	125	51.7	2.025	3.40
40	4.4	11.060	1.40	130	54.4	1.861	3.49
45	7.2	9.867	1.52	135	57.2	1.706	3.58
50	10.0	8.823	1.64	140	60.0	1.567	3.66
55	12.8	7.884	1.76	145	62.8	1.442	3.74
60	15.6	7.101	1.89	150	65.6	1.327	3.82
65	18.3	6.409	2.01	155	68.3	1.226	3.89
70	21.1	5.767	2.14	160	71.1	1.132	3.96
75	23.9	5.150	2.28	165	73.9	1.046	4.02
80	26.7	4.700	2.39	170	76.7	0.967	4.08
85	29.4	4.266	2.51				

15.12 Temperature-resistance relationship table (for T5 sensor)

Table 15.4 for T5

Temperature F	Temperature C	Electric resistance kΩ	Volt DC	Temperature F	Temperature C	Electric resistance kΩ	Volt DC
-5	-20.6	496.38	0.08	140	60.0	12.348	1.97
0	-17.8	422.97	0.09	145	62.8	11.164	2.10
5	-15.0	361.35	0.11	150	65.6	10.106	2.22
10	-12.2	309.74	0.13	155	68.3	9.193	2.34
15	-9.4	266.152	0.15	160	71.1	8.344	2.46
20	-6.7	230.462	0.17	165	73.9	7.585	2.58
25	-3.9	198.968	0.19	170	76.7	6.904	2.69
30	-1.1	172.231	0.22	175	79.4	6.313	2.80
35	1.7	149.467	0.26	180	82.2	5.761	2.92
40	4.4	130.642	0.29	185	85.0	5.263	3.02
45	7.2	113.87	0.33	190	87.8	4.815	3.13
50	10.0	99.456	0.37	195	90.6	4.410	3.23
55	12.8	87.095	0.42	200	93.3	4.057	3.33
60	15.6	76.425	0.48	205	96.1	3.724	3.42
65	18.3	67.501	0.53	210	98.9	3.423	3.51
70	21.1	59.457	0.60	215	101.7	3.149	3.60
75	23.9	52.489	0.67	220	104.4	2.910	3.67
80	26.7	46.429	0.74	225	107.2	2.689	3.75
85	29.4	41.322	0.82	230	110	2.476	3.82
90	32.2	36.682	0.90	235	112.8	2.288	3.89
95	35.0	32.619	0.99	240	115.6	2.117	3.96
100	37.8	29.068	1.09	245	118.3	1.965	4.02
105	40.6	25.948	1.19	250	121.1	1.821	4.08
110	43.3	23.291	1.29	255	123.9	1.690	4.13
115	46.1	20.855	1.39	260	126.7	1.569	4.19
120	48.9	18.708	1.51	265	129.4	1.462	4.23
125	51.7	16.809	1.62	270	132.2	1.360	4.28
130	54.4	15.184	1.73	275	135.0	1.266	4.32
135	57.2	13.682	1.85	280	137.8	1.180	4.36

16 Wiring Diagram

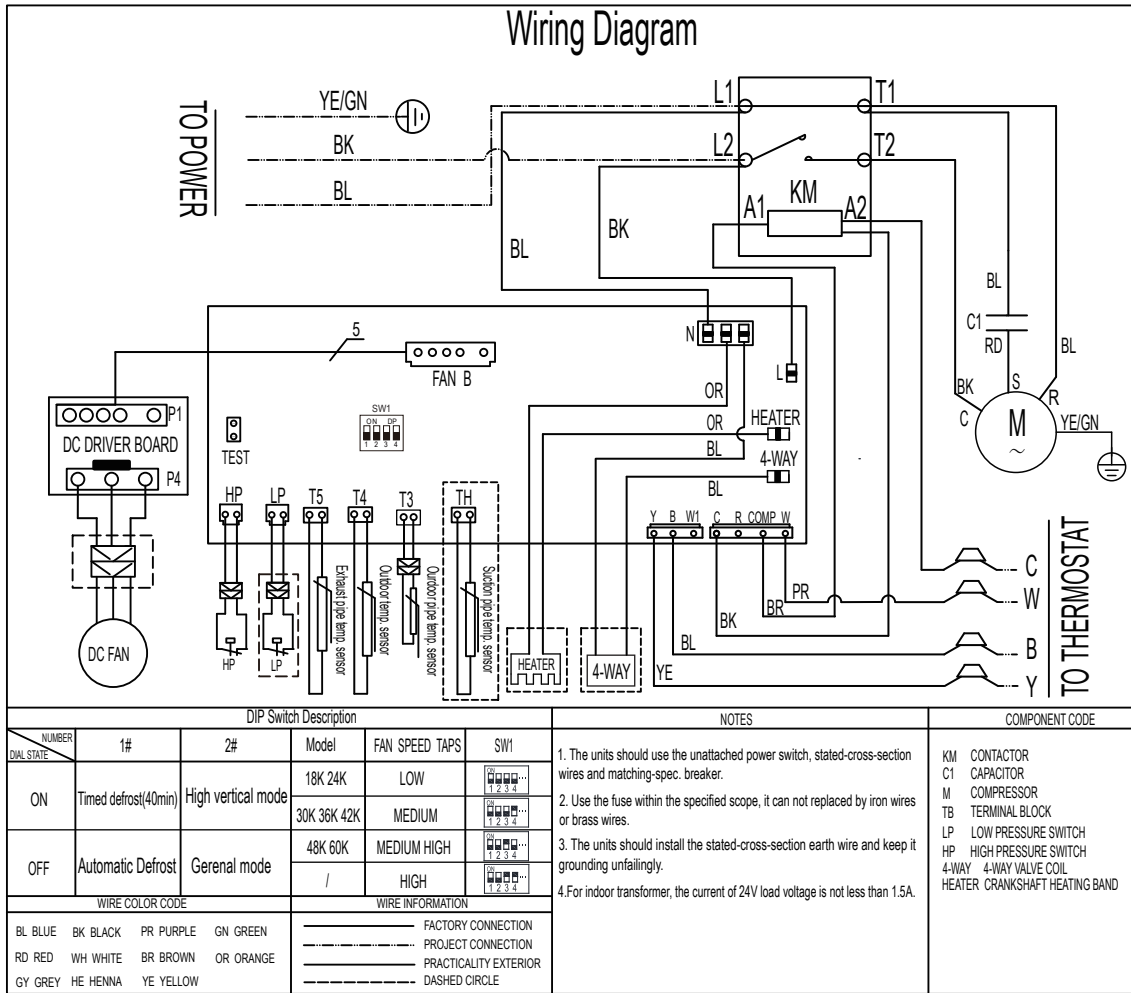

NOTE: For reference only, the actual wiring diagram shall prevail

Figure 16.1 Wiring Diagram for HP Systems

17 Cleaning and Maintenance

17.1 Cleaning Precautions



Warning:

- Any maintenance and cleaning of outdoor units can only be carried out by qualified maintenance personnel.
- Any unit maintenance can only be carried out by qualified maintenance personnel.



Caution: Electric shock

- Be sure to turn off the unit and disconnect the power supply before cleaning or maintenance.



Note:

- Do not use chemicals or chemically treated cloth to clean the unit.
- Do not use benzene, paint thinner, polishing powder or other solvents to clean this unit.



Be careful:

- When removing the filter, do not touch the metal parts in the unit. Sharp metal edges can cut you.

17.2 Pre-Season Inspection and Maintenance

At the start of each heating or cooling season, do the following:





	Turn off the unit and disconnect the power supply.
  	Check for damaged wires, check for leaks.
	Make sure that all air inlets and outlets are not blocked.

Table 17.1

Appdenix 1

High Vertical Lift Installation Requirements

1. In a completely horizontal long piping installation, if the evaporator and the condenser are at the same height (or slightly lower than the condenser), the pipeline set should be inclined towards the evaporator. This helps to reduce the refrigerant return to the condenser during the closed cycle of the air conditioning system.

2. For the installation of the system where the evaporator is located above the condenser, a reversed vapor line trap should be installed on the suction pipe before the evaporator inlet (see Figure 1). The top of the reverse loop must be slightly higher than the top of the evaporator. If the bending tool cannot be used, it can be created by brazing two 90 ° long radius elbows together. Correctly support the reverse loop and fix it at the nearest point on the indoor unit or adjacent structure.

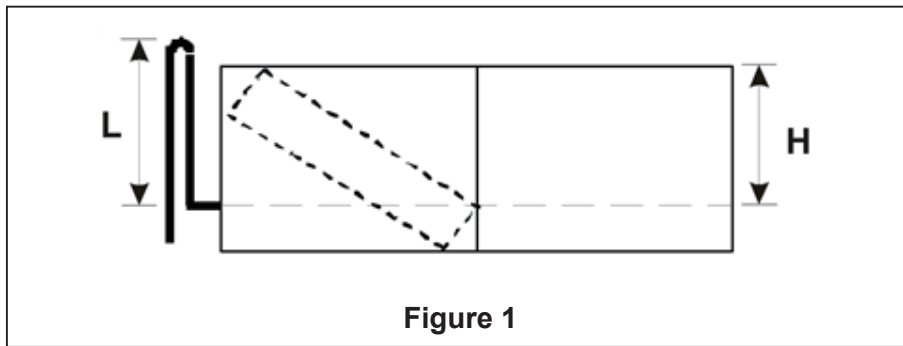

3. When the condenser is located above the evaporator and the height difference is greater than 15 ft, it is necessary to set the oil trap at the evaporator. Most HVAC supply houses have preformed oil trap, or pipe elbows can be brazed together to form oil trap(see the figure below).

Remember to add the equivalent length of the oil traps in the calculation of the equivalent length of the suction pipe. For example, if two 45 ° elbows, a short elbow and a 90 ° long elbow are used in the suction pipe with a diameter of 3/4" to construct the oil trap, the additional equivalent length is $0.7+0.7+1.7+1.5$, which is equal to 4.6 feet.

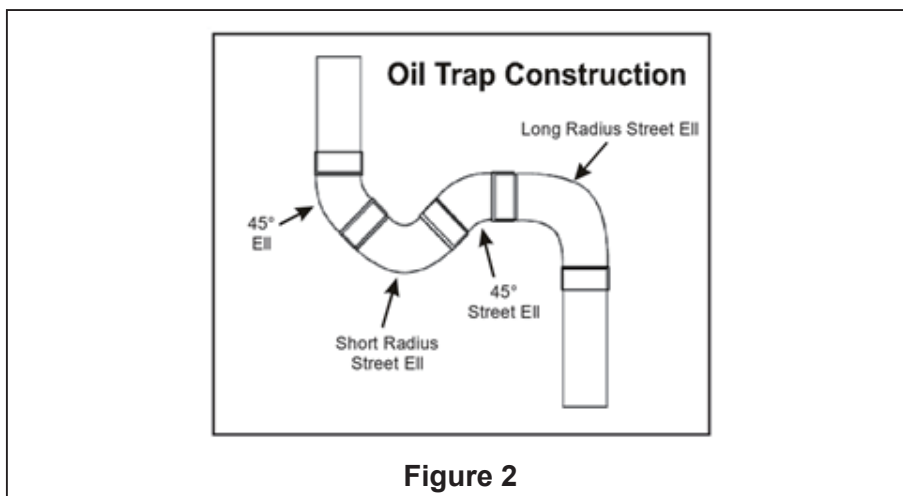

4. If oil flows back into the outdoor unit's compressor, this might cause liquid compression or deterioration of oil return. Oil traps in the rising gas piping can prevent this.
An oil trap should be installed every 6 m (20ft) of vertical suction line riser.

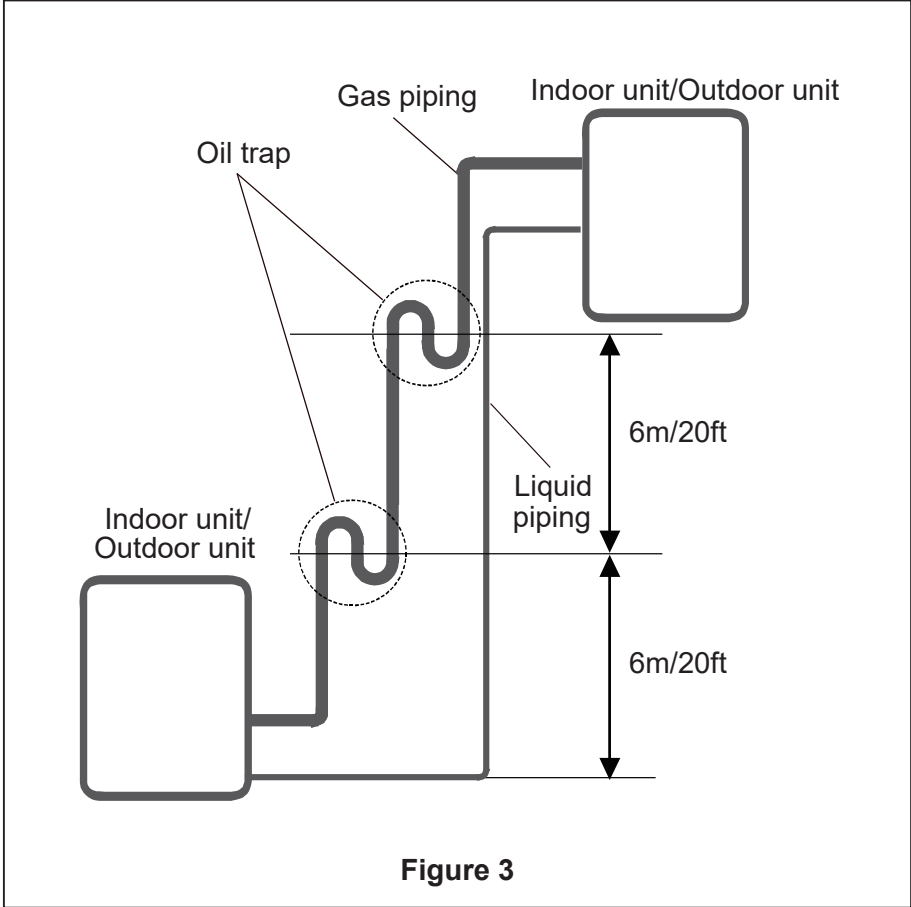

SMA-DT-ENG03.V2
802035000115

Design, material, performance specifications and components
subject to change without notice.